

**AMENDED Agenda**  
**Tolland Planning & Zoning Commission**  
21 Tolland Green, Tolland, Connecticut  
Monday, May 13, 2024 at 7:00 p.m., 6<sup>th</sup> floor – Council Chambers

---

1. **Call to Order**
2. **Pledge of Allegiance**
3. **Seating of Alternate(s)**
4. **Additions to Agenda**
5. **Public Comment** - Any person wishing to ask a question, make a comment or put forward a suggestion for any item or matter other than a public hearing item.
6. **Public Hearing(s)**
7. **Old Business**
  - 7.1. Affordable Housing Plan Update
8. **New Business**
  - 8.1. **PZC #24-4 – 16 Sugar Hill Road** - Special Permit per Section 17-2.D to construct a 50' x 50' shed that exceeds the footprint of the principal structure. Zone: Residential Design District. Applicant: Andrew Kindstedt. *Receive and set the Public Hearing for Monday, June 10, 2024.*
  - 8.2. **PZC #24-5 – 259 Hartford Turnpike** – Special Permit Modification to add ten new gravel parking spaces behind the existing building. Zone: CIZ-A. Applicant: 259 Hartford Turnpike, LLC. *Receive and set the Public Hearing for Monday, June 10, 2024.*
9. **Reports**
  - 9.1. Town Council Liaison
  - 9.2. Economic Development Liaison
  - 9.3. Capitol Region Council of Governments
  - 9.4. Zoning Enforcement Report
  - 9.5. Planning Update
10. **Other Business**
11. **Correspondence**
12. **Public Participation**
13. **Approval of Minutes** – April 22, 2024 Regular Meeting
14. **Adjournment**

To join the Zoom meeting, either click:

<https://us06web.zoom.us/j/4325402030?pwd=NG43ZHcyOXBQOGJldzZVTmQxNmhZZz09>

**One tap mobile:** +13017158592,,4325402030#,,,,\*444555#

**Or call:** 1-646-876-9923 and input:

Meeting ID: 432 540 2030

Passcode: 444555

All public business will be conducted by 11:00 p.m. unless waived by a vote of the Commission.  
Any party needing an accommodation contact the Planning & Development Department at (860) 871-3601.  
*The Town of Tolland is an Affirmative Action/Equal Opportunity Employer.*



TOWN of TOLLAND/ 21 Tolland Green, Tolland, Connecticut 06084

## MEMO

---

**TO:** Planning and Zoning Commission

**FROM:** David Corcoran, AICP, Director of Planning & Development

**DATE:** May 8, 2024

**RE:** Affordable Housing Plan Update

---

Staff has developed a second draft of the Affordable Housing Plan update for review by the Commission following feedback from the Commissioners. Once the Commission is satisfied that it has developed a final draft, Staff proposes to hold the draft plan until August before it schedules the Plan for adoption in September. Additionally, the Commission has the right per CGS 8-30(j) to hold a public hearing prior to adoption. If the Commission chooses to hold a public hearing, it must notice the hearing 35 days prior to the hearing.

The Town is required by CGS 8-30(j) to update its Affordable Housing Plan every five years. The Town initially adopted its Affordable Housing Plan on September 23, 2019 as part of the Plan of Conservation and Development. The new plan has to be adopted by September 23, 2024 by the Planning and Zoning Commission. This iteration of the plan will be separated from the POCD, with the intent to re-integrate it into the document during the 2029 POCD update process, which will likely begin in late 2027.



# Tolland Affordable Housing Plan Update

Draft 2024



## Introduction

This document is intended to serve as an update to the Housing Chapter of the 2019 POCD, in compliance with the provisions of CGS 8-30(j) that towns create a housing plan aimed at housing affordability and with the Connecticut General Statutes Section 8-23 recommendation that towns plan for housing, including affordable housing. Over the last five years the Town of Tolland has made considerable progress in encouraging and supporting the development of Affordable Housing, and looks forward to seeing how some of those regulatory changes support further development over the next several years.

Since 2019, Tolland has approved 240 new multi-family units which are currently under construction and has passed numerous regulatory changes to support the development of multi-family and affordable housing. Tolland has become one of the first communities in the northeastern part of the state with an Affordable Housing Trust Fund, and now requires any new multi-family development with at least ten units to build 5% affordable housing or make “buy-out” into that Trust Fund. Tolland now also offers a density bonus for those willing to build additional affordable units.

Residential development and housing play important roles in community, community character, and the community planning process. Housing is where jobs go at night and where households and families live their lives. Housing density, style, and tenure contribute to community character. Home ownership and housing equity have been a primary driver of wealth creation. Also, residential uses are the most predominant land use in a community and residential zoning typically dominates the land area of a town.

Residential development patterns often frame the overall development patterns of a community.

As a community that is rural-suburban in character, approximately 95% of Tolland’s land area is zoned residential, the overwhelming majority of which is zoned for single-family residential housing. Limited water and sewer drives this land use pattern. Single-family residential zoning dominates Tolland’s land area and allowable uses. Tolland’s housing stock is made up of only 93.8% single-family detached residential housing units and 1.5% single-family attached housing. Therefore, less than five percent of Tolland’s current housing stock is multi-family housing. In terms of resiliency—specifically, diversity—Tolland’s housing stock is not diverse and can be viewed as being overly susceptible to disturbances in the market.

Housing affordability and the lack of affordable housing is perhaps the greatest housing issue facing Tolland. This lack of affordable housing is directly related to the lack of housing diversity and results in limited housing options for young persons, the elderly, and other non-family households.

## Progress since the 2019 POCD

Tolland has made considerable progress in its efforts to encourage Affordable Housing since its initial Affordable Housing Plan was adopted as part of the Plan of Conservation and Development in 2019. In the past five years, the Town has:

- Created an Affordable Housing Trust Fund.
- Adopted regulations requiring any new multi-family development of at least ten units to construct at least 5

percent 8-30(g)-compliant affordable housing or pay into the Affordable Housing Trust Fund.

- Created a density bonus regulation to allow developers constructing a larger percentage of affordable housing to have up to 25% more units than a development with a smaller percentage of affordable housing.
- Revised its Affordable Housing regulations to be consistent across all zones where multi-family housing is allowed.
- Revised the Zoning Permit fee schedule to substantially reduce the fee for Special Permits for Multi-Family Housing.
- Added a provision to the Zoning Regulations for Temporary Accessible Accommodations to allow for exemptions from the Zoning Regulations where a temporary demonstrable need for accessibility exists.
- Created a floating “Master Plan Overlay Zone” option which can be used to support the furtherance of Affordable Housing.
- Updated its Accessory Dwelling Unit Regulations to comply with state statute.
- Allowed Two-Family Dwelling Units by right on lots of at least three acres.
- Approved the development of 240 new multi-family units which are currently under construction. While these were passed before the adoption of the affordable housing regulations, they will support a more diverse housing stock in Tolland.

- Commissioned a study on the fiscal and economic Impacts of Multi-Family Housing, which found a demand for additional multi-family developments and a net benefit to the Town by permitting them in appropriate locations.
- Hired a full-time Grants and Projects Manager who pursues funding opportunities, including those related to affordable housing and housing rehabilitation.

## Overall Residential Patterns



This Plan recognizes and accepts that Tolland’s rural-suburban residential development patterns, housing type, form, and density will continue, mostly as it is today.

That said, Tolland is missing multi-family and mixed-use developments that provide greater diversity in housing options and other features or amenities such as public spaces and walkable communities. As discussed in the next section on housing needs and in the economic development section, there are appropriate locations for much-needed housing opportunities beyond low-density single-family units, particularly within the Route 195 corridor. With careful consideration of location, design and density,

Tolland can maintain its overall low density pattern while providing greater opportunities for all income levels.

Therefore, this Plan does not recommend any specific changes to the single-family residential zoning, but that the Planning and Zoning Commission continues to monitor market trends and demand to ensure that the zoning is in sync with consumer needs and wants.

### **What Does “Affordable” Mean?**

This assessment primarily utilized U.S. Census data (2021) on the characteristics of housing, household income, and housing purchase and rent values in Tolland. Household income was compared to the availability of housing types at corresponding sales values and rents to determine affordability and needs.

Housing affordability is a complex concept and challenging problem. One of the challenges is that it can be defined in several ways. The Connecticut General Statutes (CGS), Chapter 126a Affordable Housing Land Use Appeals, Section 8-30g narrowly defines housing affordability as:

- Assisted Housing: housing which is receiving or will receive financial assistance under any governmental program for the construction or substantial rehabilitation of low- and moderate-income housing, and any housing occupied by persons receiving rental assistance under chapter 319uu or Section 1437f of Title 42 of the United States Code;
- Set-aside Development: a development in which not less than 30% of the dwelling units will be conveyed by deeds containing covenants or restrictions which shall require that, for at least 40 years after the initial occupation of the

proposed development, such dwelling units shall be sold or rented at or below prices which will preserve the units as housing for which persons and families pay 30% or less of their annual income, where such income is less than or equal to 80% of the median income. In a set-aside development, of the dwelling units conveyed by deeds containing covenants or restrictions, a number of dwelling units equal to not less than 15% of all dwelling units in the development shall be sold or rented to persons and families whose income is less than or equal to 60% of the median income and the remainder of the dwelling units conveyed by deeds containing covenants or restrictions shall be sold or rented to persons and families whose income is less than or equal to 80% of the median income.

The CGS 8-30g definition of housing affordability is narrow because it only includes housing units and households receiving government assistance through specified programs or housing units that are specifically deed-restricted as affordable through set-aside developments. For example, in 2022, 236 housing units or 4.33% of Tolland’s housing stock qualifies as affordable housing as defined by 8-30g (this also includes mortgage programs).

There are other types of units in Tolland that could be considered affordable, but do not meet the criteria of CGS 8-30g. For example, since the early 1990s Tolland has permitted 83 accessory dwelling units (apartments) within single-family homes. These units provide housing diversity and opportunities, most of which likely rent at affordable rates, but do not count toward Tolland’s count of affordable units.

The Connecticut Housing Finance Authority (CHFA) defines affordability based on a percentage of area median family-income and the number of persons in the family/household. CHFA uses the Hartford Metropolitan Statistical Area (MSA), which Tolland is in, and the median family income at \$118,100. For example, moderate income would be 80% of median family income (\$94,480). The Hartford MSA median household income is \$85,723, which is approximately \$35,000 less than Tolland's local median household income of \$121,120.

Another way to define housing affordability is based on how much a household can spend to purchase housing or the percentage of household income spent on housing whether for purchase or rent. This approach will be used to calculate housing affordability and need in Tolland to answer the question of whether housing in Tolland is affordable when compared to household income.

The first step is to calculate the maximum purchase price for a house that a household can afford. The commonly agreed-upon metric is that a household can afford a housing unit valued between 2.6 to 3.0 times the gross household income (with the lower limits of affordability being 2.6 and the maximum limit of affordability being 3.0). For example, a household earning \$75,000 can afford to purchase a housing unit up to a value between \$195,000 (2.6 x income) and \$225,000 (3.0 x income). For this analysis and Plan, we split the difference and use 2.8 as the affordability multiplier on home purchases/ownership.

The second method is based on the U.S. Department of Housing and Urban Development's (HUD) threshold of 30% of household income. If a household pays more than 30% of income for housing, then housing is deemed to not be affordable. For example, if the

same household earning \$75,000 per year is spending more than \$22,500 (30%) per year or \$1,875 (30%) per month on housing, then such housing is deemed to be unaffordable for that household. This 30% of household income threshold can be applied to both rental and ownership housing but will be used for rental housing in this analysis.

While these measures or thresholds provide a means for calculating the affordability of housing and will be utilized in the assessment of housing need, it is important to note that there are limits as to how these measures inform us about personal circumstances, housing need, and housing costs. While the Census data provides the statistics on households spending above and below 30% of income on housing, it does not differentiate between those households who spend a high portion because of a lack of affordable housing (housing need) and those who spend 30% or more for reasons of personal choice—status, house size, access to education, etc. While the former households are burdened by lower incomes and high-cost housing, the latter households may not suffer from the same burden or hardship. While these measures provide a metric to measure housing affordability, they fall short of informing us about the personal circumstances, choices, needs, and wants that are captured or assumed in the calculations and that affect housing affordability.

When discussing affordable housing, it is also important to address the phrase “workforce housing.” HUD, CHFA, and the Connecticut General Statutes use the phrase affordable housing to define housing that is affordable to households earning up to 80% AMI (Area Median Income). Housing advocates typically distinguish between affordable housing and workforce housing—affordable housing being up to 60% AMI and workforce housing being 60% to

120% AMI. Workforce housing is often defined as housing for service workers, such as police officers, teachers, nurses, etc. This differentiation is important in the context of Tolland and the Hartford region. For example, in the Hartford MSA with a median family income of \$118,100, a family household at 60% AMI would be earning \$70,860—by no means is this a low-income household—and a family household at 80% AMI would be earning \$94,480.

### Tolland’s Housing Stock Characteristics

The characteristics of Tolland’s housing stock provide context to understanding housing value, housing costs, and housing affordability. They also inform us about demand and how demand is organized around housing products and location. Understanding the housing characteristics and their influence on demand, market strength, and housing affordability provides insight into housing need and the strategies to address housing need.

According to the U.S. Census (2021 estimates), Tolland has 5,495 housing units, 98.4% (5,411) of which are occupied and 0.6% of which are vacant (Table 1).

Vacancy rates of less than 10% typically indicate strong demand and often signal the need for additional supply, especially in the rental housing market. Vacancy rates of less than five percent in both the rental and homeownership markets indicate a very strong market and that the vacancies are most likely the result of naturally occurring turnover. A rental vacancy rate of zero percent indicates strong demand or limited supply in the rental housing market.

**Table 1. Housing Occupancy, Tolland**

	Estimate	%
<b>Total housing units</b>	<b>5,495</b>	<b>100%</b>
<i>Occupied housing units</i>	5,411	98.4%
<i>Vacant housing units</i>	84	0.6%
<i>Homeowner vacancy rate</i>	0.7 (37/4785)	—
<i>Rental vacancy rate</i>	7.5 (47/626)	—

As noted, Tolland’s housing stock is dominated by single-unit detached housing—commonly known as single-family housing. Including single-unit attached housing, 91% of Tolland’s housing stock is considered single-family housing—a housing stock that is most favorable to homeownership (Table 2). The remaining 9% of the housing stock is in various forms of multi-family housing that include 3 to 20 or more units per building. Overall, Tolland’s housing stock lacks diversity in housing types and tenure.

The percentage of single-unit housing nearly mirrors the percentage of home ownership (Table 3). The average household size of owner-occupied units is 2.79 persons per unit compared to 1.86 persons per rental unit. This difference is likely driven by the number of bedrooms available—single-unit owner-occupied housing typically has three or more bedrooms per unit, while rental housing typically has one and two bedrooms per unit. As a result, single-unit housing and owner-occupied housing typical attract more families and school-age children than multi-family and rental housing.



**Table 2. Housing Units in Structure, Tolland**

	Estimate	%
<b>Total housing units</b>	<b>5,495</b>	<b>100%</b>
<i>1-unit detached</i>	4,943	89.9%
<i>1-unit attached</i>	59	1.1%
<i>2 units</i>	29	5.2%
<i>3 or 4 units</i>	231	2.7%
<i>5 to 9 units</i>	207	4.2%
<i>10 or more units</i>	26	0.5%
<i>Mobile home</i>	0	0.0%
<i>Boat, RV, van, etc.</i>	0	0.0%

**Table 3. Housing Tenure, Tolland**

	Estimate	%
<b>Occupied housing units</b>	<b>5,411</b>	<b>100%</b>
<i>Owner-occupied</i>	4,785	92.8%
<i>Renter-occupied</i>	626	7.2%
<i>Average household size of owner-occupied unit</i>	2.79	–
<i>Average household size of renter-occupied unit</i>	1.86	–

The median number of rooms per housing unit is 6.7 with 74.3% of Tolland's housing stock having six rooms or more (Table 4). More rooms typically indicates larger homes and more bedrooms per housing unit. Table 5 shows that 85.1% of Tolland's housing stock has three or more bedrooms and 33.3% of the housing stock has four or more bedrooms.

**Table 4. Rooms Per Housing Unit, Tolland**

	Estimate	%
<b>Total housing units</b>	<b>5,495</b>	<b>100%</b>
<i>1 room</i>	11	0.2%
<i>2 rooms</i>	64	1.2%
<i>3 rooms</i>	312	5.7%
<i>4 rooms</i>	334	6.1%
<i>5 rooms</i>	692	12.6%
<i>6 rooms</i>	1,116	20.3%
<i>7 rooms</i>	902	16.4%
<i>8 rooms</i>	1,015	18.5%
<i>9 rooms or more</i>	1,049	19.1%
<i>Median rooms</i>	6.7	–

**Table 5. Bedrooms, Tolland**

	Estimate	%
<b>Total housing units</b>	<b>5,495</b>	<b>100%</b>
<i>No bedroom</i>	11	0.2%
<i>1 bedroom</i>	424	7.7%
<i>2 bedrooms</i>	386	7.0%
<i>3 bedrooms</i>	2,845	51.8%
<i>4 bedrooms</i>	1,584	28.8%
<i>5 or more bedrooms</i>	245	4.5%

Tolland's housing stock is relatively young, with 54.6% of units built since 1980 and 18.4% built since 2000 (Table 6). A young housing stock indicates that the housing product available has modern amenities that most likely make the housing product competitive in the overall market place. This may help to explain, at least in part, the low vacancy and strong occupancy rates.

**Table 6. Year Structure Built, Tolland**

	Estimate	%
<b>Total housing units</b>	<b>5,495</b>	<b>100%</b>
<i>Built 2020 or later</i>	0	0.0%
<i>Built 2010 to 2019</i>	274	5.0%
<i>Built 2000 to 2009</i>	737	13.4%
<i>Built 1990 to 1999</i>	1,059	19.3%
<i>Built 1980 to 1989</i>	933	16.9%
<i>Built 1970 to 1979</i>	757	13.8%
<i>Built 1960 to 1969</i>	842	15.3%
<i>Built 1950 to 1959</i>	627	11.4%
<i>Built 1940 to 1949</i>	14	0.3%
<i>Built 1939 or earlier</i>	252	4.6%

Tolland's householders are mostly new to the community. A total of 78.2% of the householders moved into their housing unit since 1990 and 40.5% have moved in since 2010 (Table 7). This is generally consistent with the age of the housing stock and overall movement patterns of householders.

### Tolland's Housing Stock Cost Characteristics

This section reviews housing value and costs for owner-occupied and renter-occupied housing. Table 8 presents the value of owner-occupied housing, which can be assumed to be mostly single-family housing. Tolland's median value of housing is \$301,100 with 82.2% of owner-occupied housing valued above \$200,000. In addition, 50.3%, or half, of the owner-occupied housing is valued above \$300,000.

To afford the median owner-occupied home at \$301,000 in Tolland, a household would need an income of \$84,308 ( $\$301,000 \times 0.28$ ). This income is well below Tolland's median household income of

\$121,120 and about the same as the Hartford MSA median household income of \$85,723. Of the 4,726 owner-occupied housing units, 69.6% have a mortgage (Table 9).

**Table 7. Year Householder Moved into Unit, Tolland**

	Estimate	%
<b>Occupied housing units</b>	<b>5,411</b>	<b>100%</b>
<i>Moved in 2019 or later</i>	610	11.3%
<i>Moved in 2015 to 2018</i>	929	17.1%
<i>Moved in 2010 to 2014</i>	657	12.1%
<i>Moved in 2000 to 2009</i>	1,187	21.6%
<i>Moved in 1990 to 1999</i>	850	15.7%
<i>Moved in 1989 and earlier</i>	1,178	21.8%

**Table 8. Value, Owner-Occupied Housing, Tolland**

	Estimate	%
<b>Owner-occupied units</b>	<b>4,785</b>	<b>100%</b>
<i>Less than \$50,000</i>	84	1.8%
<i>\$50,000 to \$99,999</i>	22	0.5%
<i>\$100,000 to \$149,999</i>	142	3.0%
<i>\$150,000 to \$199,999</i>	602	12.6%
<i>\$200,000 to \$299,999</i>	1,526	31.9%
<i>\$300,000 to \$499,999</i>	2,059	43.0%
<i>\$500,000 to \$999,999</i>	275	5.7%
<i>\$1,000,000 or more</i>	75	1.6%
<b>Median</b>	<b>\$301,100</b>	<b>---</b>

Tables 10 and 11 respectively provide the Selected Monthly Owner Costs (SMOC) for housing units with and without a mortgage. The SMOC, as explained by the U.S. Census, “are calculated from the sum of payment for mortgages, real estate taxes, various insurances, utilities, fuels, mobile home costs, and condominium fees.” They provide a good estimate of the cost of buying and owning a home. The median SMOC for housing units with a mortgage is \$3,331 and \$2,329 for housing units without a mortgage.

**Table 9. Mortgage Status, Tolland**

	Estimate	%
<b>Owner-occupied units</b>	<b>4,785</b>	<b>100%</b>
<i>Housing units with a mortgage</i>	3,331	69.6%
<i>Housing units without a mortgage</i>	1,454	30.4%

Table 12 provides the Selected Monthly Owner Costs as a Percentage of Household Income (SMOCAPI). The U.S. Census explains, the SMOCAPI “is used to measure housing affordability and excessive shelter costs. For example, many government agencies define excessive as costs that exceed 30 percent of household income.” Based on the SMOCAPI, 16% of Tolland’s households with a mortgage and 11.3% of households without a mortgage are paying 30% or more of their household income on housing costs. Based on this SMOCAPI, approximately 27.3% (or 698) of Tolland’s owner-occupied housing is unaffordable. However, these calculations do not inform us whether the cost of housing in excess of 30% of household income is the result of need (and a burden on income) or want (a personal choice).

**Table 10. Selected Monthly Owner Costs (SMOC) – With Mortgage, Tolland**

	Estimate	%
<b>Housing units with a mortgage</b>	<b>3,331</b>	<b>100%</b>
<i>Less than \$500</i>	0	0.0%
<i>\$500 to \$999</i>	95	2.9%
<i>\$1,000 to \$1,499</i>	507	15.2%
<i>\$1,500 to \$1,999</i>	631	18.9%
<i>\$2,000 to \$2,499</i>	657	19.7%
<i>\$2,500 to \$2,999</i>	636	19.1%
<i>\$3,000 or more</i>	805	24.2%
<b>Median</b>	<b>\$2,329</b>	<b>---</b>

**Table 11. Selected Monthly Owner Costs (SMOC) – Without Mortgage, Tolland**

	Estimate	%
<b>Housing units without a mortgage</b>	<b>1,454</b>	<b>100%</b>
<i>Less than \$250</i>	26	1.8%
<i>\$250 to \$399</i>	18	1.2%
<i>\$400 to \$599</i>	90	6.2%
<i>\$600 to \$799</i>	479	32.9%
<i>\$800 to \$999</i>	271	18.6%
<i>\$1,000 or more</i>	570	39.2%
<b>Median</b>	<b>\$862</b>	<b>---</b>

Table 13 presents the Gross Rent paid for occupied rental units and Table 14 provides the Gross Rent as a Percentage of Household Income (GRAPI). The median gross rent is \$1,424 and 38.8% of the households pay more than \$1,500 per month for rent. However, 271 (or 76.9%) of the rental households are spending 30% or more of their household income on rent—the unaffordable housing threshold set by government standards. As noted above, what these calculations do not inform us about is if the cost of housing in

excess of 30% of household income is the result of need (and a burden on income) or want (a personal choice).

**Table 12. Selected Monthly Owner Costs as Percentage of Household Income (SMOCAPI), Tolland**

	Estimate	%
<b>Housing units with a mortgage</b>	<b>3,331</b>	<b>100%</b>
Less than 20.0 percent	1,866	57.1%
20.0 to 24.9 percent	557	16.7%
25.0 to 29.9 percent	310	9.3%
30.0 to 34.9 percent	173	5.2%
35.0 percent or more	361	10.8%
<b>Housing unit without a mortgage</b>	<b>1,454</b>	<b>100%</b>
Less than 10.0 percent	492	33.8%
10.0 to 14.9 percent	418	28.7%
15.0 to 19.9 percent	192	13.2%
20.0 to 24.9 percent	102	7.0%
25.0 to 29.9 percent	73	5.0%
30.0 to 34.9 percent	0	0%
35.0 percent or more	164	11.27%
<b>Not computed</b>	<b>77</b>	<b>---</b>

Based on owner- and renter-occupied housing costs and percentage of household income being spent on housing costs, 969 (17.9%) of occupied housing units have households spending 30% or more on housing. This illustrates Tolland’s housing affordability challenge. However, this does not inform us about housing needs. To determine housing need, we need to do further analysis.

**Table 13. Gross Rent, Tolland**

	Estimate	%
<b>Occupied units paying rent</b>	<b>529</b>	<b>100%</b>
Less than \$500	27	5.1%
\$500 to \$999	16	3.0%
\$1,000 to \$1,499	297	56.1%
\$1,500 to \$1,999	113	21.4%
\$2,000 to \$2,499	76	14.4%
\$2,500 to \$2,999	0	0.0%
\$3,000 or more	0	0.0%
<b>Median (dollars)</b>	<b>\$1,424</b>	<b>---</b>
<b>No rent paid</b>	<b>97</b>	<b>---</b>

**Table 14. Gross Rent as Percentage of Household Income (GRAPI), Tolland**

	Estimate	%
<b>Occupied units paying rent (excluding units where GRAPI cannot be computed)</b>	<b>352</b>	<b>100</b>
Less than 15.0 percent	27	7.7%
15.0 to 19.9 percent	0	0.0%
20.0 to 24.9 percent	13	17.2%
25.0 to 29.9 percent	41	3.7%
30.0 to 34.9 percent	16	4.5%
35.0 percent or more	255	72.4%
<b>Not computed</b>	<b>274</b>	<b>---</b>

### Tolland’s Household Income

This analysis will generally determine which segments of the housing market are most challenged by housing affordability by indicating at which incomes and price point housing is most needed. Household income, housing value, rent values, and types of household are analyzed to determine which segments of the housing market are underserved by Tolland’s housing stock.

**Table 15. Income by Household, Tolland**

	All Households	Families	Married-Couple Families	Nonfamily
<b>Total</b>	<b>5,411</b>	<b>4,289</b>	<b>3,887</b>	<b>1,122</b>
Less than \$14,999	7.3%	1.9%	0.0%	27.9%
\$15,000 to \$24,999	4.1%	1.9%	2.1%	12.3%
\$25,000 to \$34,999	4.0%	2.1%	2.0%	11.3%
\$35,000 to \$49,999	5.8%	6.7%	5.5%	7.3%
\$50,000 to \$74,999	10.6%	9.8%	8.7%	8.1%
\$75,000 to \$99,999	9.5%	9.9%	10.7%	7.8%
\$100,000 to \$149,999	19.1%	21.0%	21.9%	12.7%
\$150,000 to \$199,999	18.2%	19.8%	20.9%	10.7%
\$200,000 or more	21.5%	26.7%	28.2%	1.8%
<b>Median income</b>	<b>\$121,120</b>	<b>\$139,743</b>	<b>\$145,469</b>	<b>\$63,486</b>

Table 15 presents households and household incomes by Total Households, Family Households, Married-Couple Family Households, and Non-Family Households. The Census defines each of these household categories as follows:

- Household [Total]: all of the people who occupy a housing unit.

- Family Household: contains at least one person related to the householder by birth, marriage, or adoption.
- Married-Couple Family: a husband and wife enumerated as members of the same household. The married couple may or may not have children living with them. The expression "married-couple" before the term "family" indicates that the household or family is maintained by a husband and wife.
- Nonfamily Household: a householder living alone (a one-person household) or where the householder shares the home exclusively with people to whom he/she is not related.

The breakdown of income by household categories reveals meaningful differences. While the median household income in Tolland for all households is \$121,120, family median income is \$139,743, married-couple family median income is \$145,469, and non-family median income is \$63,486. For sake of comparison, households, families, and non-family households will be used. Married-couple families, since they are a sub-set with the families category, will not be used. However, we should keep in mind that married-couple families—as part of family-households—have the highest median household income.

Family households account for 79.2% of households and non-family households account for 20.7%. Of the family households, 67.5% earn at least \$100,000 (the minimum income cohort nearest the median household income of \$121,120) per year. Conversely, 74.7% of non-family households earn less than \$100,000 per year. This indicates that non-family households are more likely to experience housing affordability challenges than family households. However, it should not be assumed that non-family households are of lesser socio-

economic status since 13.3% of Tolland’s households (9.6% of owner-occupied and 41.7% of renter-occupied housing) are one-person (i.e., one income) households).

This difference in family and non-family income is dramatic, but not surprising based on the number of one-person households and the characteristics of Tolland’s housing stock. As noted earlier, 89.9% (or 4,943 units) of Tolland’s housing stock is single-unit detached housing—approximately 20% more than the 4,152 family households. Single-family detached housing is commonly occupied by families. Tolland’s housing market, historically and today, has been priced for two-income households.

At this point, based on family and married-couple family median incomes (\$139,743 and \$145,469, respectively) it is fair to assume that most but not all family households can secure housing in Tolland that is affordable, even though some family households may be paying more than 30% of their household income on housing. It is possible that some or all the family-households paying more than 30% of their household income are doing so by choice rather than need. It is also fair to assume that non-family households, based on a relatively lower median household income of \$63,486, face the greatest housing affordability challenges in Tolland. It also is possible that some or many non-family households paying more than 30% of their household income are doing so out of need, not by choice. However, at this point, these assumptions are simply reasonable speculations based on what we know so far about housing costs and household incomes.

**Assessing Tolland’s Housing Need**

This next assessment is to determine housing need by analyzing household income by household type and comparing it to Tolland’s

existing housing stock by tenure. The method employed presents the Household Income (Table 16-A) data in eight cohorts ranging from less than \$15,000 per year to \$150,000 or more per year. Then, based on the higher end of each household income cohort, the affordable housing value is calculated at 2.8 times household income for owner-occupied housing and the affordable rent value is calculated at 30% of household income.

Census data (Table 15) on the percentage (converted to a raw number) of household by income was utilized to determine the number of households in each income cohort. In addition, the Census data (Table 8) was used to determine the number of housing units in the eight housing value cohorts ranging from less than \$50,000 to \$1,000,000 or more for owner-occupied housing. The number of housing units valued within the household income cohort was then assumed to represent the number of households within that income cohort being served by those housing units. The same approach was used for rental housing, gross rents, and the number of units in each gross rent cohort as household (Table 13).

To calculate housing need, the number of households with incomes adequate to afford the estimated affordable home value (or rent value) were subtracted from the existing housing units at the approximate value or rent. The result of the calculation is the ‘Units Available Vs Adequate Income’ line in the tables. A negative value indicates fewer units available at the given price point than households with the income to afford them. A positive value indicates more units available than households with the income to afford them. The negative values indicated housing need—regarding affordability—at that price point and housing income segment of the housing market.

**Table 16-A. Households by Income Compared to Existing Owner-Occupied Housing Stock by Value**

Household Income	<\$15,000	\$15,000- \$24,999	\$25,000- \$34,999	\$35,000- \$49,999	\$50,000- \$74,999	\$75,000- \$99,999	\$100,000- \$149,999	\$150,000+
Households @ Income	395	222	216	314	574	514	1,034	2,148
Est. affordable home Value (HH Income x 2.8) (rounded)	\$42,000	\$70,000	\$98,000	\$140,000	\$210,000	\$280,000	\$420,000	\$560,000
Existing Housing (Household) Units	84 (1.8%)	22 (0.5%)	89 (1.9%)	142 (3.0%)	1,425(29.8%) )	703 (14.7%)	2,059 (43.0%)	270 (5.6%)
Households w/Adequate Income	395 (7.3%)	222 (4.1%)	216 (4.0%)	314 (5.8%)	574 (10.6%)	514 (9.5%)	1034 (19.1%)	2,148 (39.7%)
<b>Units Available Vs Adequate Income</b>	<b>-310</b>	<b>-200</b>	<b>-127</b>	<b>-172</b>	<b>851</b>	<b>189</b>	<b>1,025</b>	<b>-1,878</b>
Total Households	5,411	5,411	5,411	5,411	5,411	5,411	5,411	5,411

This method is not perfect. Census household income cohorts do not perfectly match housing and rent value cohorts. Calculating home value affordability or rent value affordability at a specific income does not capture the affordability of the entire income cohort. That said, the calculations provide a general understanding of the relationship between income and housing value/rent and distribution of household income and housing value/rent. It provides insight into which segments of the housing market are and are not being served by housing affordability.

Tables 20-A & B present calculations for all households and housing units in Tolland. Table 16-A presents owner-occupied housing and Table 16-B presents rental housing.

Tables 21-A & B present calculations for family-households in Tolland. Table 21-A presents owner-occupied housing and Table 21-B presents rental housing.

Tables 22-A & B present calculations for non-family-households in Tolland. Table 22-A presents owner-occupied housing and Table 22-B presents rental housing.

Table 16-A compares household income to the value of owner-occupied housing in Tolland. The table shows that there are more housing units available than there are households with incomes between \$50,000 and \$149,999. This indicates that there is no housing affordability issue or housing need for owner-occupied housing valued between approximately \$210,000 and \$420,000. For household incomes above \$150,000 and housing valued over \$560,000 there are fewer housing units available than there are households. Therefore, at the higher-end of the Tolland's housing market, there are ample households with high income to afford the available housing stock.

The housing need is the greatest for lower-income cohorts with household incomes below \$50,000, which is approximately 41% of local median household income. There are 637 fewer ownership

housing units available than the total number of households in this segment of the market which can only afford housing valued below \$100,000. Most concerning, the households at incomes below \$25,000 (approximately 20.6% of local median household income) total 510 more households than available ownership housing units. Overall, this signifies that the greatest need for affordable housing is at and below 30% local median household income or ownership housing valued below \$100,000. This may, in part, help to explain why 16% of Tolland's households with a mortgage and 11.3% of households without a mortgage are paying 30% or more of their household income on housing costs (Table 12).

It is important to note that Table 16-A focuses on ownership housing (primarily single-family housing) compared to all households in Tolland. This means that some of those lower-income households who cannot afford owner-occupied housing might be able to afford rental housing.

Table 16-B provides the same comparisons and calculations for rental housing. The greatest housing affordability issue and need for rental housing is at incomes below \$50,000. There are fewer rental housing units available than there are households at incomes below \$50,000 (there are 807 more households at incomes below \$50,000 than there are rental housing units available). In addition, at 30% of household income, the maximum affordable rent is \$1,250 per month, yet 30.1% of the rental housing available in Tolland is priced at or above \$1,500 per month. Furthermore, approximately 54.3% of the rental housing in Tolland is affordable to households with incomes less than \$50,000.

The issue and need for affordable housing are more evident when we recognize that 92.8% of Tolland's housing stock is owner-

occupied and only 7.2% (or 626 units) is rental housing. This raises further concerns when we consider the make-up of Tolland's households and the median household income. As discussed above, Tolland's median household income is \$121,120, family median income is \$139,743, married-couple family median income is \$145,469, and non-family median income is \$63,486. Family households total 79.2% of households and married-couple households total 71.8%. Family and married-couple households with higher median household incomes than Tolland's median household income are least likely to be challenged by a lack of affordable housing. Therefore, it is the non-family households whose median household income is \$63,486 or 52.4% of Tolland's median household income, who are most likely to be burdened by the lack of affordable housing. There are 1,122 non-family households and approximately only 337 housing units that are affordable to a household earning \$60,000 per year. Of those 1,122 non-family households 522 are living alone and 283 of those living alone are householders over the age of 65 (Table 17).

Tolland's housing is not affordable to many of its residents or to many residents in the greater regional housing market. Tolland has a need for more affordable housing at certain price points or incomes at or below \$70,000. While the \$70,000 median household income is 57.7% of Tolland's median household income, it is 81.6% of the Hartford MSA median household income. The point being, a median household income of \$70,000 is by no means low-income.



**Table 16-B. Households by Income Compared to Existing (Rental) Housing Stock by Value**

Household Income	<\$15,000	\$15,000- \$24,999	\$25,000- \$34,999	\$35,000- \$49,999	\$50,000- \$74,999	\$75,000- \$99,999	\$100,000- \$149,999	\$150,000+
Households @ Income	395	222	216	314	574	514	1,034	2,148
Est. affordable monthly rent Value (HH Income x 0.30)	\$375	\$625	\$875	\$1,250	\$1,875	\$2,500	\$3,750	\$3,750+
Existing Housing (Household) Units	15 (2.4%)	28 (4.5%)	18 (28.8%)	279 (44.6%)	189 (30.2%)	0 (0%)	0 (0%)	0 (0%)
Households w/Adequate Income	395 (7.3%)	222 (4.1%)	216 (4.0%)	314 (5.8%)	574 (10.6%)	514 (9.5%)	1034 (19.1%)	2,148 (39.7%)
<b>Units Available Vs Adequate Income</b>	<b>-380</b>	<b>-194</b>	<b>-198</b>	<b>-35</b>	<b>-385</b>	<b>-514</b>	<b>-1,034</b>	<b>-2,148</b>
Total Households	5,411	5,411	5,411	5,411	5,411	5,411	5,411	5,411

**Table 17. Household Size, Type, and Children**

Household Type	Occupied Units	Occupied %	Owner Units	Owner %	Rental Units	Rental %
<b>Occupied Housing Units</b>	<b>5,411</b>	<b>100%</b>	<b>4,785</b>	<b>100%</b>	<b>626</b>	<b>100%</b>
1 – Person Household	722	13.3%	461	9.6%	261	41.7%
2 – Person Household	2,207	40.8%	1,987	41.5%	220	35.1%
3 – Person Household	1,121	20.7%	1,005	21.0%	116	18.5%
4-or-more– Person Household	1,361	25.2%	1,332	27.8%	29	4.6%
<b>Family Households</b>	<b>4,289</b>	<b>79.2%</b>	<b>4,159</b>	<b>86.9%</b>	<b>130</b>	<b>20.8%</b>
Married-Couple Family	3,887	71.8%	3,785	79.1%	102	16.3%
Household 65+	844	15.6%	829	17.3%	15	2.4%
Other Family	402	7.4%	374	7.8%	28	44.7%
<b>Non-Family Households</b>	<b>1,122</b>	<b>20.7%</b>	<b>626</b>	<b>13.1%</b>	<b>496</b>	<b>79.2%</b>
Household Living Alone	522	9.6%	461	9.6%	261	41.7%
Householder 65+	283	5.2%	231	4.8%	52	8.3%
Householder Not Living Alone	400	7.4%	165	3.4%	235	37.5%
Householder 65+	56	1.0%	56	1.2%	0	0.0%

### Understand Housing Need Versus Housing Demand

Need and demand are not the same. Just because there is a need for affordable housing at certain price points does not mean there is actual demand for the construction of new housing at such price points. Housing demand is driven by job growth, population growth, and ultimately, household formations—new households being formed from growth in jobs, growth in population, or splits of existing households into two or more households (e.g. divorce, adult children moving out of their parent’s house, etc.). Connecticut and the Hartford Metropolitan Region have experienced stagnant job and population growth over the past 30 years. Housing demand-drivers overall are weak and demand for new housing has been driven mostly by household formations, functional obsolescence of existing housing units, and the replacement of demolished housing units.

To understand demand in Tolland, specifically the absorption of new housing into the Tolland housing market, housing permit data for a 26-year period from 1997 to 2023 was reviewed). During this period, 1,311 new housing units were constructed. Of these, 1,252 (95.5%) were single-family dwellings, six were 2-unit dwellings, and 52 were multi-family (5+) unit dwellings. A total of fifteen units were demolished, resulting in a net gain of 1,308 housing units. This results in an absorption rate of 50.4 units per year over the 26-year period. The greatest activity occurred in 2000 with 153 units constructed and the slowest year was 2016 with seven units constructed.

Year	Number of Permits					ADU	Demo	Net Gain
	Total Units	1 Unit	2 Unit	3 & 4 Units	5 Units or More			
2023	14	11	0	0	0	3	2	12
2022	25	25	0	0	0	1	0	26
2021	14	14	0	0	0	4	0	18
2020	11	9	2	0	0	2	0	13
2019	6	6	0	0	0	1	1	7
2018	13	13	0	0	0	1	0	14
2017	13	13	0	0	0	-	0	13
2016	7	7	0	0	0	-	2	5
2015	7	7	0	0	0	-	1	6
2014	17	13	4	0	0	-	3	14
2013	10	10	0	0	0	-	0	10
2012	8	8	0	0	0	-	0	8
2011	8	8	0	0	0	-	0	8
2010	10	10	0	0	0	-	0	10
2009	10	10	0	0	0	-	0	10
2008	18	18	0	0	0	-	0	18
2007	55	39	0	0	16	-	0	55
2006	57	57	0	0	0	-	0	57
2005	95	59	0	0	36	-	1	94
2004	87	87	0	0	0	-	1	86
2003	95	95	0	0	0	-	1	94
2002	98	98	0	0	0	-	0	98
2001	92	92	0	0	0	-	0	92
2000	153	153	0	0	0	-	1	152
1999	149	149	0	0	0	-	1	148
1998	137	137	0	0	0	-	0	137
1997	104	104	0	0	0	-	1	103
<b>Total</b>	<b>1,311</b>	<b>1,252</b>	<b>6</b>	<b>0</b>	<b>52</b>	<b>95*</b>	<b>15</b>	<b>1,308</b>

\*83 ADUs were permitted prior to 2017

**Table 18. Housing Permits by Year, Tolland**

In analyzing Tolland’s capacity to increase its affordable housing percentage, the first objective is to ensure that enough affordable housing is created each year so as to not decrease the current percentage (4.33%) of qualified affordable housing units in accordance with 8-30g. The second objective is to work toward meeting the 10% threshold of qualified affordable housing units in accordance with 8-30g.

Today, the 4.33% of qualified affordable housing (units that count towards Tolland’s 10%) equals 236 housing units. Many of these are actually income qualified mortgages. This means the unit is not preserved as affordable but rather the current owner has a type of mortgage that counts towards Tolland’s total. If that household moves, that unit no longer counts towards Tolland’s percentage.

To reach 10%, based on the existing 5,495 total housing units, Tolland would need 550 qualified housing unit, or 314 more qualified units than exist today. However, keeping in mind that the numerator and denominator are moving targets, Tolland would need to create approximately 60 affordable qualified housing units per year over the next 10 years (or 600 total units), if 500 total housing units were built over that period. Adding 60 units of affordable-qualified housing per year or 600 such units over 10-years, exceeds the total historical and anticipated absorption rate and therefore is unreasonable to expect.

Instead, Tolland should set a target or aspirational goal that 20% to 25% of new housing constructed will be affordable. This would require approximately 11 to 15 affordable qualified units per year—if the historical rate of new housing construction and absorption were achieved. These targets would produce between 110 and 150 affordable qualified units over the next 10 years and would go a long

way towards increasing Tolland’s affordable housing supply. Regardless of the total units constructed per year, Tolland should remain focused on the percentage of affordable units constructed per year. Most important, the qualified affordable housing should target household incomes at or below \$70,000 (approximately 60% and below) of Tolland’s median household income.

**Addressing Housing Need**

Affordable housing is about more than just housing price. Income along with regional or macro scale markets and local (micro) scale sub-markets, all play roles. Affordable housing problems cannot be solved simply at the local level or by any individual community. This does not absolve individual communities from their role or responsibility to address affordable housing needs but rather provides context to the challenge of doing so.

Since the local housing market does not have the capacity to provide the needed affordable housing units, the focus shifts away from trying to solve the problem of affordable housing to making a good-faith effort to provide much-needed affordable housing over the next ten years. Tolland can encourage affordable housing for those members of the community and region who are most challenged by the expense of housing. Tolland must be intentional and strategic in its efforts or interventions. Being intentional means that Tolland must want to address housing needs and provide affordable housing by having the political will to embrace and help the most vulnerable households. Being strategic means that Tolland must adopt strategies (policies and programs) aimed specifically at the outcome of improving housing affordability or providing affordable housing. In 2023, the Tolland Economic Development Commission paid for a study which identified a realistic need for

approximately 250 additional multifamily units in addition to the 240 that were entitled in 2022.

### **Overall or Macro-Scale Considerations**

Affordable Housing Need: Focus on housing need more than tenure (owner vs renter) or type (single vs multi-family). The desired outcome is to provide affordable housing and not worry about what form it comes in. While this plan contains recommendations for some specific types, overall Tolland should encourage and promote affordable housing opportunities in all forms.

The Town should continue to partner with non-profit housing providers to create affordable units. Most recently the Town successfully worked with a non-profit to convert a former school to elderly housing.

Multi-Family Housing: Tolland lacks housing diversity and is over-reliant on single-family detached housing. The Town should encourage and seek to increase its multi-family housing stock to somewhere between 10% to 15% of total housing. Multi-family housing provides the greatest opportunity to increase the percentage of affordable housing units.

Tolland should seek diversity within its mix of multi-family units. Decreases in household size and increases in single- and two-person households are creating the need for more one- and two-bedroom units. As a general guideline, the Town should seek to provide the following mix of units in multi-family housing developments:

- 30% to 40% 1-bedroom
- 40% to 50% 2-bedroom

- 5% to 15% 3-bedroom units

While the market and developers will drive the proposed mix of units, developers should be cognizant of this desired mix, and the Planning and Zoning Commission should question applicants to explain deviations from this mix. This mix should be reviewed on a regular basis and adapted accordingly.

Crumbling Foundations: Over a dozen communities in eastern Connecticut have experienced the issue of cracking and crumbling foundations, including at least 140 housing units within Tolland. The cause of this issue has been traced to a specific quarry and the existence of a mineral called pyrrhotite in the stone aggregate that was used to mix concrete. The Town continues to work with property owners to resolve this issue to preserve the existing housing stock.

### **Zoning Considerations**

The following zoning strategies are designed to intentionally intervene in housing affordability and housing need by encouraging and providing more affordable housing.

Inclusionary Zoning: Tolland has passed regulations requiring five percent of housing in any housing development of ten or more units to meet the requirements of affordable housing under 8-30g.

Zoning Density: Tolland should continue to work with the development community to identify appropriate residential densities to allow for developers to build profitable developments that add affordable units to the Town's housing stock consistent with the zones they are located in.

Affordable Housing Provisions: Review, revise, and consolidate the Affordable Housing provisions contained in Sections 5.5 (Flexible Residential Development), 7.6 (Workforce Housing Required), and 9.6 (Multi-Family Developments). Such a provision should include:

- Affordable housing regulations that apply to all residential development, including single-family subdivisions of five or more lots.
- Affordable housing requirements of five percent to 15% of units depending of the size, character, location, and availability of sewer and water.
- Density bonuses for percentage of affordable units, including additional bonuses for units in excess of 15%.
- Requirements for Housing Affordability Plans that are submitted by developers in accordance with 8-30g and other applicable State Statutes.
- The elimination of provisions that may be barriers to the inclusion or construction of affordable units (e.g., large minimum lot sizes, number of parking spaces, etc.).

Elderly Housing: Allow private market elderly housing and require 15% to 25% to be affordable and compliant with 8-30g. There is need for elderly housing in Tolland and the greater regional market. The Town can help satisfy that need and provide affordable housing for a population that needs options.

8-30g Application: Create a 'friendly' 8-30g zoning regulation that allows for and establishes a process for 8-30g development applications. Ideally this should be created as a floating zone, where

the underlying zoning remains, but a developer can choose to use the provisions in the floating zone. The intent is to be proactive rather than having an 8-30g application forced upon the community. This enables an 8-30g-compliant development to be designed by the Town, not the developer.

Mixed-Use Development:

The location of mixed-use developments should be confined to areas served by sewers or capable of being served by sewer, particularly within the Route 195 corridor. To encourage and facilitate such developments, the Planning and Zoning Commission has created a 'Master Plan Overlay Zone' that provides flexible standards for the development of housing as part of the mixed-use development.

Accessory Dwelling Units: Tolland recently overhauled its accessory dwelling unit regulations to allow more opportunities including detached 'tiny houses'. The Town should continue to allow and encourage accessory dwellings. This plan does not recommend attempting to address the 10% required affordable housing threshold set by 8-30g with accessory dwelling units. Such requirements and restrictions could become barriers to accessory dwelling units and would create enforcement obstacles.

These units provide housing opportunity, diversity, and market-rate affordability, helping those who need options and more affordable housing. Despite not counting towards Tolland's affordable housing percentage, they provide affordable housing alternatives.

## Permitting and Taxes

**Permitting Fees:** Tolland has reduced permitting fees for new multi-family development, but could further consider reducing permit fees for affordable housing units. This could include land use applications, zoning, and building permits. Entitlements and permitting create real costs for housing development. The entitlement processes often run between three and six percent of the total development cost. While this percentage may seem low, it is meaningful when the return-on-investment with high risk runs between 12% and 15%. Reducing fees can be a viable means of incentivizing affordable housing.

**Tax Incentives:** Consider providing tax incentives for affordable units in multi-family and mixed-use developments. One barrier to providing affordable units is the reduced return-on-investment. The cost to construct such units, if they are to be the same or similar standard of market units, can be as much as the market units. Reduced sales value or rents can and do undermine the financial feasibility of affordable units and possibly the whole development project.

Tax incentives, along with reduced permitting fees, can provide a real incentive for constructing affordable housing units. Tax incentives could range from 10% to 100%, from one to 10 years, and could be for the affordable units only or the whole development. Tax incentives have become common for multi-family residential development.

A possible incentive structure could be 100% of post-occupancy real property taxes for the first two years, 75% for year three, 50% in year four, and 25% in year five (or years five through seven).



## Accessible Housing

While the legal requirements of housing accessibility are directed by the Americans with Disabilities Act (ADA) and the State Building Code, legal requirements and minimums often address the populations with greatest needs but fall short of addressing those who do not meet the legally-defined need. The fact is, a greater percentage of the population suffers from challenges of physical limitation and mobility than those populations served by accessibility laws.

Tolland has an aging population as evidenced by a median age 42.2 years, higher than the national and state median age. Approximately 20% of Tolland's population and 22% of Tolland's households are 65 years of age or older. They are more likely to have physical and mobility limitation or more likely will in the future.

Recognizing that the percentage of over-65 population will increase over the next ten years, Tolland should strive to encourage and even require housing that is accessible. The following are some

examples of considerations and policies that Tolland may want to encourage:

- At or near grade entrances to housing units—as few steps as possible.
- Wider doors for entrances, bedrooms, and bathrooms.
- First floor master bedroom suites in single family housing.
- Shower stalls in place of bathtubs and/or walk-in bathtubs.
- Handrails in baths and showers and near toilets.

While strict percentage requirements for accessible units are not needed, the Planning and Zoning Commission could encourage or strive for 20% to 25% of all new units to be accessible based on the percentage of over-65 populations.

# Summary of Housing Goals

The following summarizes strategies contained in this Plan and those strategies carried forward from the 2019 POCD. For details behind each item, refer back to the appropriate section of this POCD.

## Goals Accomplished since the 2019 POCD:

1. Encourage and seek to increase the multi-family housing stock to between 10% to 15% of total housing.\*  
*Comment: The Town has approved an additional 240 units of multi-family development since 2019, which will increase the Town's percentage of multi-family housing from 8.9% to approximately 12%.*
2. Review, revise, and consolidate the affordable housing provisions in the Zoning Regulations, per the recommendations in this Plan.\*
3. Continue to allow and encourage accessory dwelling units.\*  
*Comment: The ADU regulations were updated to meet recent changes to state statute*
4. Consider reducing permit fees for affordable housing units.\*  
*Comment: Special Permit fees for new multifamily development have been considerably reduced.*

## New Goals:

5. Work with the development community to identify appropriate residential densities to support affordable housing development while creating desirable developments.

## Ongoing Goals:

6. Maintain Tolland's overall rural-suburban development patterns, form, and density, while providing greater opportunities for all income levels.\*
7. Monitor market trends and demand to ensure that the zoning is in sync with consumer needs and wants.\*
8. Guide higher density housing and multi-family development to areas that can best support it.\*  
*Comment: The Town has revised regulations in the TVA and TCZ, and created a Master Plan Overlay Zone opportunity to support multi-family development. Recommend retaining this goal in the new plan.*
9. Encourage and promote affordable housing opportunities in all forms.\*  
*Comment: The Town has created an Affordable Housing Trust Fund and required new developments with at least 10 units to provide at least 5% Affordable Housing or pay into the Trust Fund. Recommend retaining this goal in the new plan.*



10. Continue to partner with non-profit housing providers to create affordable units.\*

11. Set a target or aspirational goal that 5% to 10% of new housing constructed will be affordable.

*Comment: The Town has created an Affordable Housing Trust Fund and required new developments with at least 10 units to provide at least 5% Affordable Housing or pay into the Trust Fund with a density bonus to promote up to 25% affordable units in new developments.*

12. Encourage diversity in number of bedrooms in multi-family units per the guidelines in this Plan.\*

*Comment: Revised regulations do not require any sort of specific bedroom count in individual multi-family units, allowing the market to determine the appropriate diversity.*

13. Amend the Zoning Regulations to allow private market elderly housing, with 15% to 25% units affordable and compliant with 8-30g.\*

14. Create a zoning provision for mixed use development which, among other requirements, requires affordable housing.\*

*Comment: Progress has been made through TVA/TCZ regulation revisions and adoption of Affordable Housing requirements.*

15. Inventory state and town owned surplus properties to determine potential use for housing.\*

16. Determine the location for additional income- and asset-restricted senior units and seek funding.\*

17. Continue to utilize tools to ensure that existing housing units are maintained and updated to meet needs, particularly for seniors.\*

18. Investigate tools to convert existing housing units into affordable units.\*

19. Continue tax programs for income-qualified seniors.\*

20. Share the Town's strategies for meeting housing needs with entities that help to create affordable housing.\*

21. Encourage home-builders to create accessible units, striving for 20% to 25% of all new units to be accessible.\*

22. Continue to alleviate the challenges and costs associated with crumbling foundations to preserve the existing housing stock.\*



TOWN OF TOLLAND  
PLANNING AND ZONING COMMISSION  
APPLICATION FOR SITE PLAN OR SPECIAL PERMIT APPROVAL

PZC # 24-4

What are you applying for? (check one):

Site Plan (new)

Site Plan Modification

Special Permit (new)\*

Special Permit Modification\*

*\*Most special permit applications require submittal of a site plan, with no additional fee for site plan required.*

Property Information	
Property Address:	<u>16 Sugar Hill Rd</u>
Property Owner:	<u>Andrew R &amp; Julie S Kindstedt</u>
Zone: <u>RDD</u>	Map/Block/Lot: <u>15 1 40</u>

Applicant Information	
Applicant Name:	<u>Andrew Kindstedt</u>
Mailing Address:	<u>16 Sugar Hill Rd</u>
Phone Number: <u>860-76-9150</u>	Email Address: <u>arkracing@hotmail.com</u>

Applicable Section of the Zoning Regulations which pertains to the proposed activity:

Describe proposed buildings, site work, and use:
<u>Detached Garage Size 50x50</u>
<u>Large Lot in Area with unusually small house</u>

Please submit the following with this form:

1. The fee must be submitted to be considered a complete application.
2. 7 paper copies and a pdf of the full plans, including all items required on the plans pursuant to Zoning Regulations.
3. The check list contained in Section 20-10 of the Zoning Regulations with an explanation of any submittal requirements for which the applicant seeks a waiver.

All of the above statements and the statements contained in any documents and plans submitted herewith are true to the best of my knowledge:

Applicant Signature: Ad [Signature] Date: 5/9/2024

Property Owner Signature\*: Ad [Signature] Date: 5/9/2024

\*Or submit signed letter authorizing applicant to submit application on property owner's behalf.

OFFICE USE ONLY

P&Z # \_\_\_\_\_

Administration	
Town Fee:	\$300.00
State DEEP Fee:	\$60.00
Engineering Rev Fee:	-
Form of Payment:	cash
Date Submitted:	5/9/24
Date of Receipt:	
Legal Notice Dates:	
Date of Decision:	
Legal Notice of Decision:	
Extensions: (if any)	

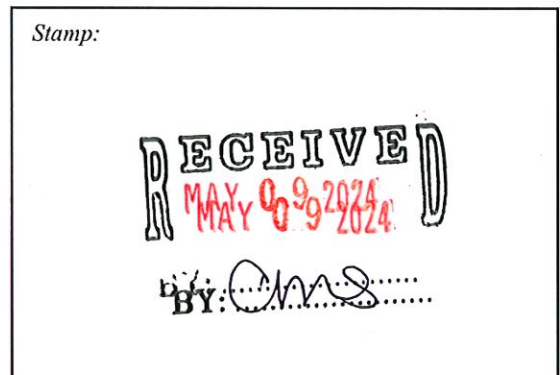

Description:

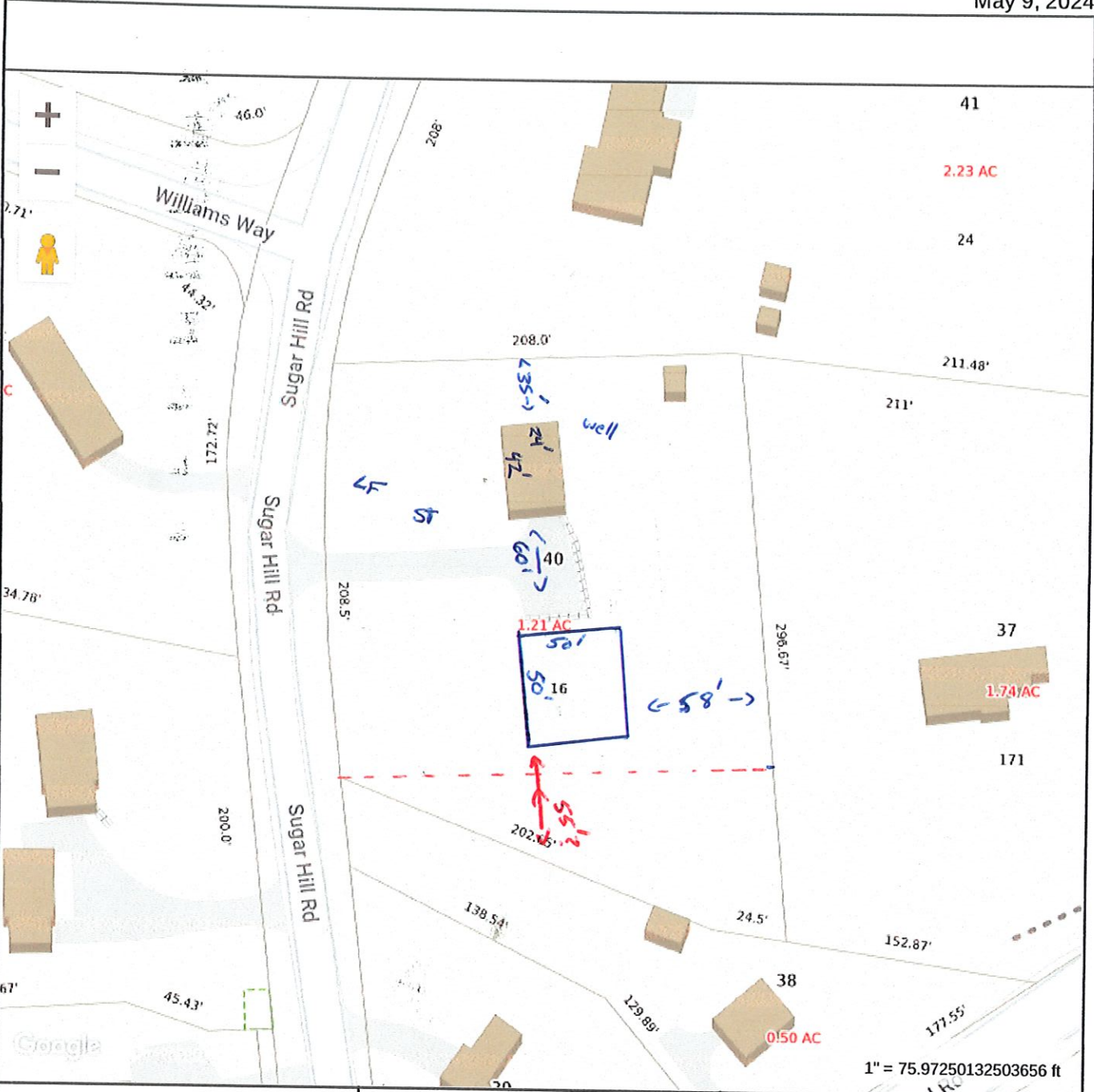



**MAP FOR REFERENCE ONLY  
NOT A LEGAL DOCUMENT**

Town of Tolland, CT makes no claims and no warranties, expressed or implied, concerning the validity or accuracy of the GIS data presented on this map.

Geometry updated October 25, 2021  
Data updated daily

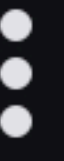
Print map scale is approximate. Critical layout or measurement activities should not be done using this resource.



» 3D DESIGN TOOL

# Steel Building 3D Design Tool

SIMPSON STEEL BUILDING COMPANY 3D Design Tool

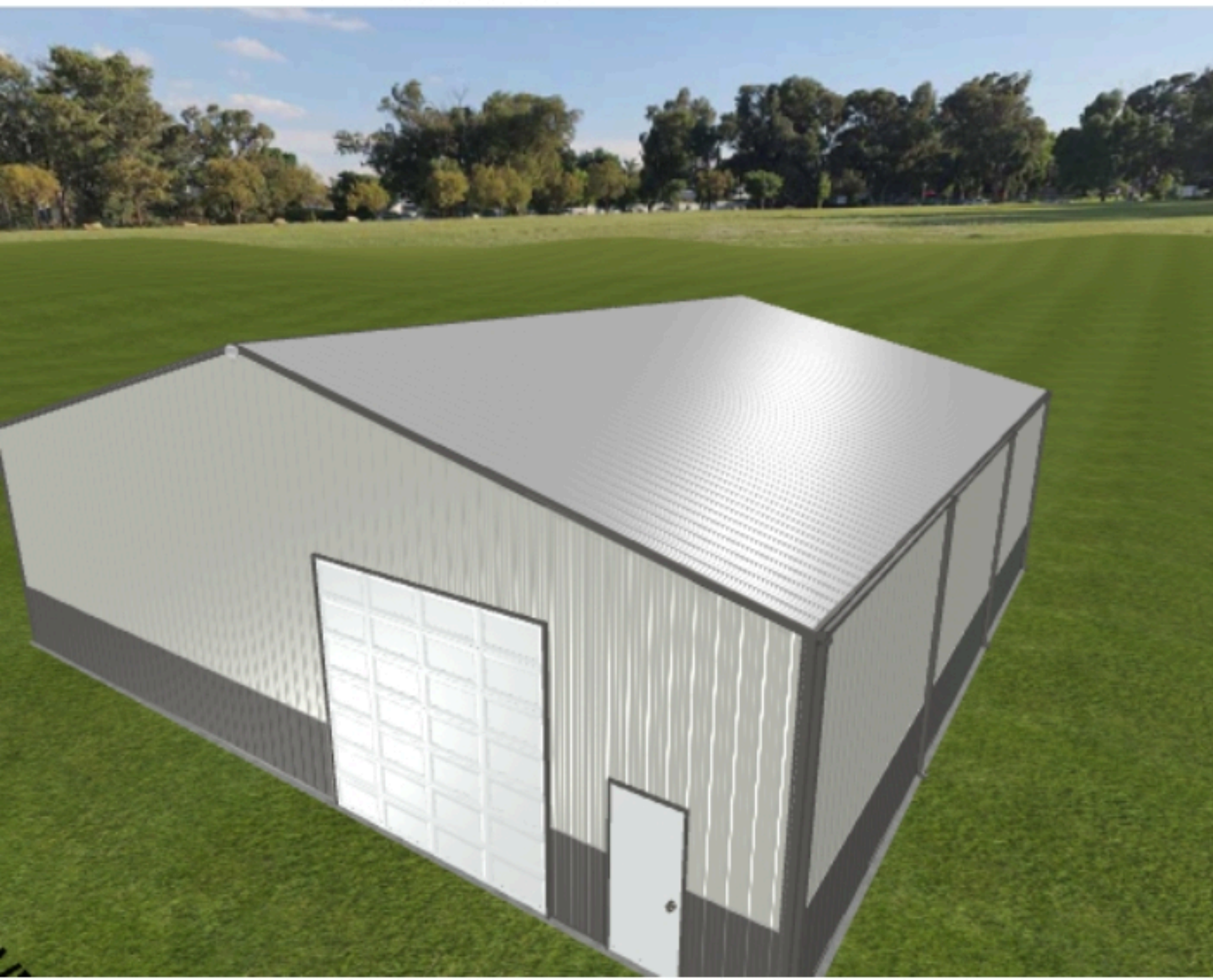

Walls	
Enclosed Left	<input checked="" type="checkbox"/>
Enclosed Right	<input checked="" type="checkbox"/>
Wainscot Front	<input checked="" type="checkbox"/>
Wainscot Back	<input type="checkbox"/>
Wainscot Left	<input type="checkbox"/>
Wainscot Right	<input checked="" type="checkbox"/>
Roof Options	
F Gable Overhang	<input type="text" value="0"/>
B Gable Overhang	<input type="text" value="0"/>
L Eave Overhang	<input type="text" value="0"/>
R Eave Overhang	<input type="text" value="0"/>
Gutters and Downspouts	<input checked="" type="checkbox"/>
Lean-tos	
Porch	
Windows & Doors	

## STATE SPOTLIGHT

- Alabama Steel Buildings
- Arizona Steel Buildings
- California Steel Buildings
- Colorado Steel Buildings
- Florida Steel Buildings
- Georgia Steel Buildings
- Illinois Steel Buildings
- Indiana Steel Buildings
- Iowa Steel Buildings
- Kansas Steel Buildings
- Kentucky Steel Buildings
- Louisiana Steel Buildings
- Maine Steel Buildings
- Michigan Steel Buildings
- Minnesota Steel Buildings
- Mississippi Steel Buildings
- Missouri Steel Buildings
- Montana Steel Buildings
- Nebraska Steel Buildings
- Nevada Steel Buildings
- New Hampshire Steel Buildings
- New Jersey Steel Buildings
- New Mexico Steel Buildings
- New York Steel Buildings
- North Carolina Steel Buildings
- North Dakota Steel Buildings
- Ohio Steel Buildings
- Oklahoma Steel Buildings
- Oregon Steel Buildings
- Pennsylvania Steel Buildings
- Rhode Island Steel Buildings
- South Carolina Steel Buildings
- South Dakota Steel Buildings
- Tennessee Steel Buildings
- Texas Steel Buildings
- Utah Steel Buildings
- Vermont Steel Buildings
- Virginia Steel Buildings
- Washington Steel Buildings
- West Virginia Steel Buildings
- Wisconsin Steel Buildings
- Wyoming Steel Buildings



1117 Solitude Drive  
 Van Buren, AR 72956  
 800-255-7624

Contact Us



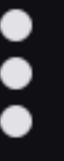

» 3D DESIGN TOOL

# Steel Building 3D Design Tool

SIMPSON STEEL BUILDING COMPANY 3D Design Tool



Walls	
Enclosed Left	<input checked="" type="checkbox"/>
Enclosed Right	<input checked="" type="checkbox"/>
Wainscot Front	<input checked="" type="checkbox"/>
Wainscot Back	<input type="checkbox"/>
Wainscot Left	<input type="checkbox"/>
Wainscot Right	<input checked="" type="checkbox"/>
Roof Options	
F Gable Overhang	<input type="text" value="0"/>
B Gable Overhang	<input type="text" value="0"/>
L Eave Overhang	<input type="text" value="0"/>
R Eave Overhang	<input type="text" value="0"/>
Gutters and Downspouts	<input checked="" type="checkbox"/>
Lean-tos	
Porch	
Windows & Doors	

## STATE SPOTLIGHT

- Alabama Steel Buildings
- Arizona Steel Buildings
- California Steel Buildings
- Colorado Steel Buildings
- Florida Steel Buildings
- Georgia Steel Buildings
- Illinois Steel Buildings
- Indiana Steel Buildings
- Iowa Steel Buildings
- Kansas Steel Buildings
- Kentucky Steel Buildings
- Louisiana Steel Buildings
- Maine Steel Buildings
- Michigan Steel Buildings
- Minnesota Steel Buildings
- Mississippi Steel Buildings
- Missouri Steel Buildings
- Montana Steel Buildings
- Nebraska Steel Buildings
- Nevada Steel Buildings
- New Hampshire Steel Buildings
- New Jersey Steel Buildings
- New Mexico Steel Buildings
- New York Steel Buildings
- North Carolina Steel Buildings
- North Dakota Steel Buildings
- Ohio Steel Buildings
- Oklahoma Steel Buildings
- Oregon Steel Buildings
- Pennsylvania Steel Buildings
- Rhode Island Steel Buildings
- South Carolina Steel Buildings
- South Dakota Steel Buildings
- Tennessee Steel Buildings
- Texas Steel Buildings
- Utah Steel Buildings
- Vermont Steel Buildings
- Virginia Steel Buildings
- Washington Steel Buildings
- West Virginia Steel Buildings
- Wisconsin Steel Buildings
- Wyoming Steel Buildings



1117 Solitude Drive  
 Van Buren, AR 72956  
 800-255-7624

Contact Us



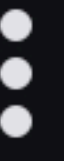

» 3D DESIGN TOOL

# Steel Building 3D Design Tool

SIMPSON STEEL BUILDING COMPANY 3D Design Tool



Walls	
Enclosed Left	<input checked="" type="checkbox"/>
Enclosed Right	<input checked="" type="checkbox"/>
Wainscot Front	<input checked="" type="checkbox"/>
Wainscot Back	<input type="checkbox"/>
Wainscot Left	<input type="checkbox"/>
Wainscot Right	<input checked="" type="checkbox"/>
Roof Options	
F Gable Overhang	<input type="text" value="0"/>
B Gable Overhang	<input type="text" value="0"/>
L Eave Overhang	<input type="text" value="0"/>
R Eave Overhang	<input type="text" value="0"/>
Gutters and Downspouts	<input checked="" type="checkbox"/>
Lean-tos	
Porch	
Windows & Doors	

## STATE SPOTLIGHT

- Alabama Steel Buildings
- Arizona Steel Buildings
- California Steel Buildings
- Colorado Steel Buildings
- Florida Steel Buildings
- Georgia Steel Buildings
- Illinois Steel Buildings
- Indiana Steel Buildings
- Iowa Steel Buildings
- Kansas Steel Buildings
- Kentucky Steel Buildings
- Michigan Steel Buildings
- Minnesota Steel Buildings
- Mississippi Steel Buildings
- Missouri Steel Buildings
- Montana Steel Buildings
- North Carolina Steel Buildings
- North Dakota Steel Buildings
- Ohio Steel Buildings
- Oklahoma Steel Buildings
- Oregon Steel Buildings
- Pennsylvania Steel Buildings
- Rhode Island Steel Buildings
- Tennessee Steel Buildings
- Texas Steel Buildings
- Utah Steel Buildings
- Virginia Steel Buildings
- Washington Steel Buildings
- West Virginia Steel Buildings
- Wisconsin Steel Buildings
- Wyoming Steel Buildings



1117 Solitude Drive  
 Van Buren, AR 72956  
 800-255-7624

Contact Us



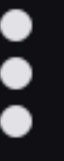

» 3D DESIGN TOOL

# Steel Building 3D Design Tool

SIMPSON STEEL BUILDING COMPANY 3D Design Tool



Submit for a Free quote

Print

Share

Save

Reset View

Look Inside

Hide Walls

### Building Dimensions

Width (ft) 50

Length (ft) 50

Height (ft) 14

### Environment

Ground Clearing

### Colors

Roof Color Galvalume

Wall Color Ash Gray

Trim Color Charcoal Gray

Large Door Polar White

Wainscot Color Charcoal Gray

## STATE SPOTLIGHT

- Alabama Steel Buildings
- Arizona Steel Buildings
- California Steel Buildings
- Colorado Steel Buildings
- Florida Steel Buildings
- Georgia Steel Buildings
- Illinois Steel Buildings
- Indiana Steel Buildings
- Iowa Steel Buildings
- Kansas Steel Buildings
- Kentucky Steel Buildings
- Louisiana Steel Buildings
- Maine Steel Buildings
- Michigan Steel Buildings
- Minnesota Steel Buildings
- Mississippi Steel Buildings
- Missouri Steel Buildings
- Montana Steel Buildings
- Nebraska Steel Buildings
- Nevada Steel Buildings
- New Hampshire Steel Buildings
- New Jersey Steel Buildings
- New Mexico Steel Buildings
- New York Steel Buildings
- North Carolina Steel Buildings
- North Dakota Steel Buildings
- Ohio Steel Buildings
- Oklahoma Steel Buildings
- Oregon Steel Buildings
- Pennsylvania Steel Buildings
- Rhode Island Steel Buildings
- South Carolina Steel Buildings
- South Dakota Steel Buildings
- Tennessee Steel Buildings
- Texas Steel Buildings
- Utah Steel Buildings
- Vermont Steel Buildings
- Virginia Steel Buildings
- Washington Steel Buildings
- West Virginia Steel Buildings
- Wisconsin Steel Buildings
- Wyoming Steel Buildings



1117 Solitude Drive  
Van Buren, AR 72956  
800-255-7624

Contact Us





















**TOWN OF TOLLAND  
PLANNING AND ZONING COMMISSION  
APPLICATION FOR SITE PLAN OR SPECIAL PERMIT APPROVAL**

PZC # 24-5

What are you applying for? (check one):

Site Plan (new)

Special Permit (new)\*

Site Plan Modification

Special Permit Modification\*

*\*Most special permit applications require submittal of a site plan, with no additional fee for site plan required.*

Property Information	
Property Address:	259 Hartford Turnpike Tolland CT. 06084
Property Owner:	259 Hartford Turnpike, LLC
Zone: <u>CIZ-A</u>	Map/Block/Lot: <u>Map 19 Block B Lot 4</u>

Applicant Information	
Applicant Name:	259 Hartford Turnpike, LLC
Mailing Address:	45 Eastdale Ave. North Suite 200 Poughkeepsie NY 12603
Phone Number:	845-635-2000
Email Address:	feberhard@kirchhoffcompanies.com

*ABushnell@BUSHnellassociatesllc.com*

Applicable Section of the Zoning Regulations which pertains to the proposed activity:
Section 19.1.D.2 Waiver Requested Due to Nature and Intensity of Proposed Use

Describe proposed buildings, site work, and use:
Proposing 10 new RV parking spots in two new processed aggregate surfaced locations behind the existing building.
Adding one RV parking spot (pavement marking) to existing paved location behind the existing building.
Please see attached drawing.



Please submit the following with this form:

1. The fee must be submitted to be considered a complete application.
2. 7 paper copies and a pdf of the full plans, including all items required on the plans pursuant to Zoning Regulations.
3. The check list contained in Section 20-10 of the Zoning Regulations with an explanation of any submittal requirements for which the applicant seeks a waiver.

All of the above statements and the statements contained in any documents and plans submitted herewith are true to the best of my knowledge:

Applicant Signature: Fred Berhard Jr Date: 5/8/2024  
 Property Owner Signature\*: Fred Berhard Jr Date: 5/8/2024  
\*Or submit signed letter authorizing applicant to submit application on property owner's behalf.

OFFICE USE ONLY

P&Z # \_\_\_\_\_

Administration	
Town Fee:	\$150.
State DEEP Fee:	\$60
Engineering Rev Fee:	
Form of Payment:	check
Date Submitted:	5/9/24
Date of Receipt:	
Legal Notice Dates:	
Date of Decision:	
Legal Notice of Decision:	
Extensions: (if any)	



Description:

## Section 20-10. Items to Be Shown on Plans

Item	Type of Application	
	Special Permit	Site Plan
<b>The Basics</b>		
<input checked="" type="checkbox"/> Plan sheets shall be 24" X 36".	X	X
<input checked="" type="checkbox"/> The plans shall be drawn to a scale of one inch equals 40 feet. One inch equals 50 feet or one inch equals 100 feet may be used if the parcel size warrants such a scale. If a scale of one inch equals 100 feet is used, areas where details are required for review purposes shall be shown at a scale of one inch equals 40 feet.	X	X
<input checked="" type="checkbox"/> Graphic scale, date of drawing and of all revisions, and name of person preparing Site Plan.	X	X
<input checked="" type="checkbox"/> A north arrow, labeled, and its relation to magnetic north.	X	X
<input checked="" type="checkbox"/> Title block.	X	X
<input checked="" type="checkbox"/> Address of property, lot number, and name and address of owner of record.	X	X
<input type="checkbox"/> Letter of authorization by property owner, permitting staff and Commissioners to enter and inspect the subject property.	X	X
<input checked="" type="checkbox"/> Engineer's seal and signature and/or surveyor's seal and signature.	X	X
<input checked="" type="checkbox"/> Name and signature of certified soil scientist.		X
<input checked="" type="checkbox"/> Commission signature block on the first sheet.	X	X
<b>Zoning</b>		
<input checked="" type="checkbox"/> Zone and zone boundaries of subject property and all property within five hundred (500) feet.	X	
<input type="checkbox"/> Aquifer Protection Overlay Zone boundary.	X	X
<b>Surroundings</b>		
<input checked="" type="checkbox"/> A 1,000-scale key map showing location of the property with respect to nearby streets, adjacent properties, municipal boundaries and notable landmarks.	X	X
<input type="checkbox"/> A 200-scale plan showing all properties or portions which fall within 500 feet of any part of the subject property. Such properties shall be identified. The information must be as per the most current Assessor's records.	X	X
<input checked="" type="checkbox"/> Town line locations if within 500 feet of the site of the proposal.	X	X
<b>Property Details</b>		
<input checked="" type="checkbox"/> Property boundaries, dimensions and area, as shown on an A-2 survey.	X	X
<input checked="" type="checkbox"/> General topographic features of the site.	X	X
<input checked="" type="checkbox"/> Existing and proposed contours drawn at two-foot intervals, including location and elevation of bench marks.		X
<input checked="" type="checkbox"/> Wooded areas, wood lines, hedgerows and unique topographic and geological features such as substantial rock outcrops and large boulders.		X
<input checked="" type="checkbox"/> Locations of all existing and proposed buildings, structures and uses, including but not limited to stone walls, sidewalks, curbing, driveways, parking and loading areas and abutting streets.	X	X
<input checked="" type="checkbox"/> Easements, rights-of-way, open spaces, identified, labeled and dimensioned as appropriate.		X
<input type="checkbox"/> Area of the site to be disturbed and/or developed in square feet and as a percentage of entire site.	X	X
<input checked="" type="checkbox"/> Total area of building footprints and gross usable floor area of each and total thereof.	X	X
<input type="checkbox"/> Area of existing and proposed impervious surfaces in square feet and as a percentage of entire site.	X	X
<input checked="" type="checkbox"/> Proposed "limit of work line" outside of which no land or natural features will be disturbed.		X
<input checked="" type="checkbox"/> Wetland boundaries and watercourses as established by a certified soil scientist, including minimum wetland buffers.		X
<input checked="" type="checkbox"/> Dimensions of all yards as required by these Regulations, including frontage of established building line if used in lieu of street frontage.	X	X
<input checked="" type="checkbox"/> Locations and descriptions of water supply and sewage disposal facilities, including the location of primary and reserve septic systems if required.	X	X
<input checked="" type="checkbox"/> Conceptual storm drainage plan.	X	
<input checked="" type="checkbox"/> A storm drainage plan in compliance with the Town of Tolland Design Manual, including the calculations for existing and proposed conditions for all drainage structures on and off the property which may be affected by this proposal.		X

## Section 20-10. Items to Be Shown on Plans

Item	Type of Application	
	Special Permit	Site Plan
<input checked="" type="checkbox"/> Stream encroachment lines as established by DEEP.	X	X
<input checked="" type="checkbox"/> Flood hazard areas as shown on Flood Insurance Rate Map, including panel number.	X	X
<input checked="" type="checkbox"/> Road names, rights-of-way and pavement widths.	X	X
<input checked="" type="checkbox"/> Edges of existing pavement, curb cuts and drainage structures within 300 feet of the site.		X
<input checked="" type="checkbox"/> Street curve data.		X
<input checked="" type="checkbox"/> Typical pavement section.		X
<input type="checkbox"/> Indication from DOT that plans were submitted for review or that review is not required.		X
<input checked="" type="checkbox"/> Adjacent utility poles and numbers.	X	X
<input checked="" type="checkbox"/> A soil erosion and sediment control plan in accordance with Article 4.		X
<input checked="" type="checkbox"/> Location, data and dates of deep pit and percolation test sites, if required.	X	X
<input checked="" type="checkbox"/> A landscape plan prepared by a licensed landscape architect, per Section 19-3.		X
<input checked="" type="checkbox"/> Lighting plan per Section 19-4.		X
<input checked="" type="checkbox"/> Statement of easements and deed restrictions which affect the plan.		X
<input checked="" type="checkbox"/> Any other similar information determined necessary by the Commission in order to provide for the proper enforcement of these Regulations.	X	X

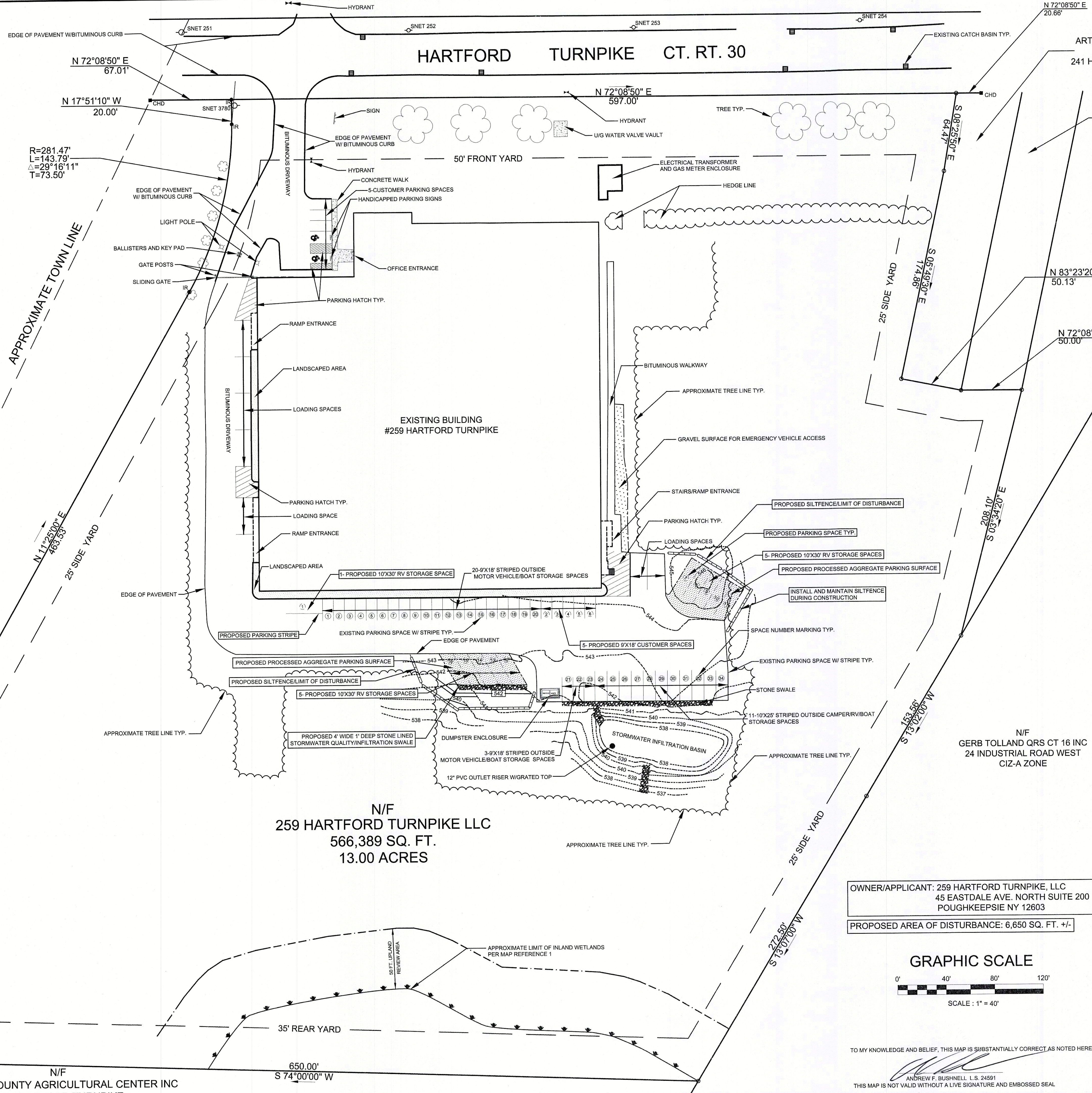
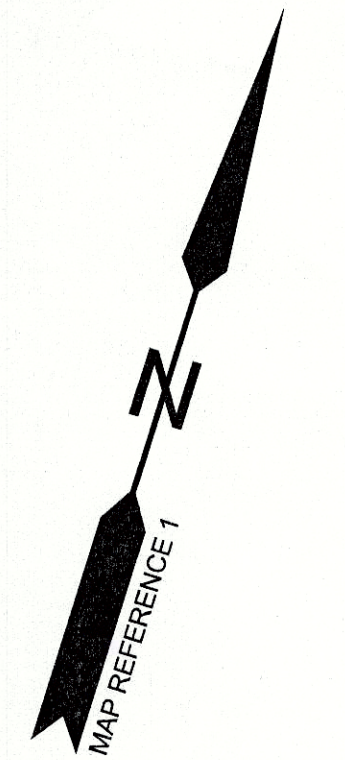

N/F  
TOLLAND COUNTY AGRICULTURAL  
CENTER INC  
269 HARTFORD TURNPIKE  
MAIL: 24 HYDE AVE. ROUTE 30  
VERNON, CT. 06066  
CIZ-A ZONE

N/F  
ARTHUR J. & NOREEN J.  
EDGAR  
241 HARTFORD TURNPIKE  
CIZ-A ZONE

N/F  
JONATHAN DION  
239 HARTFORD TURNPIKE  
CIZ-A ZONE

N/F  
FREDERICK P. JR. & DAWN  
CAMICHAEL  
235 HARTFORD TURNPIKE  
CIZ-A ZONE

KEY MAP  
SCALE 1"=1000'

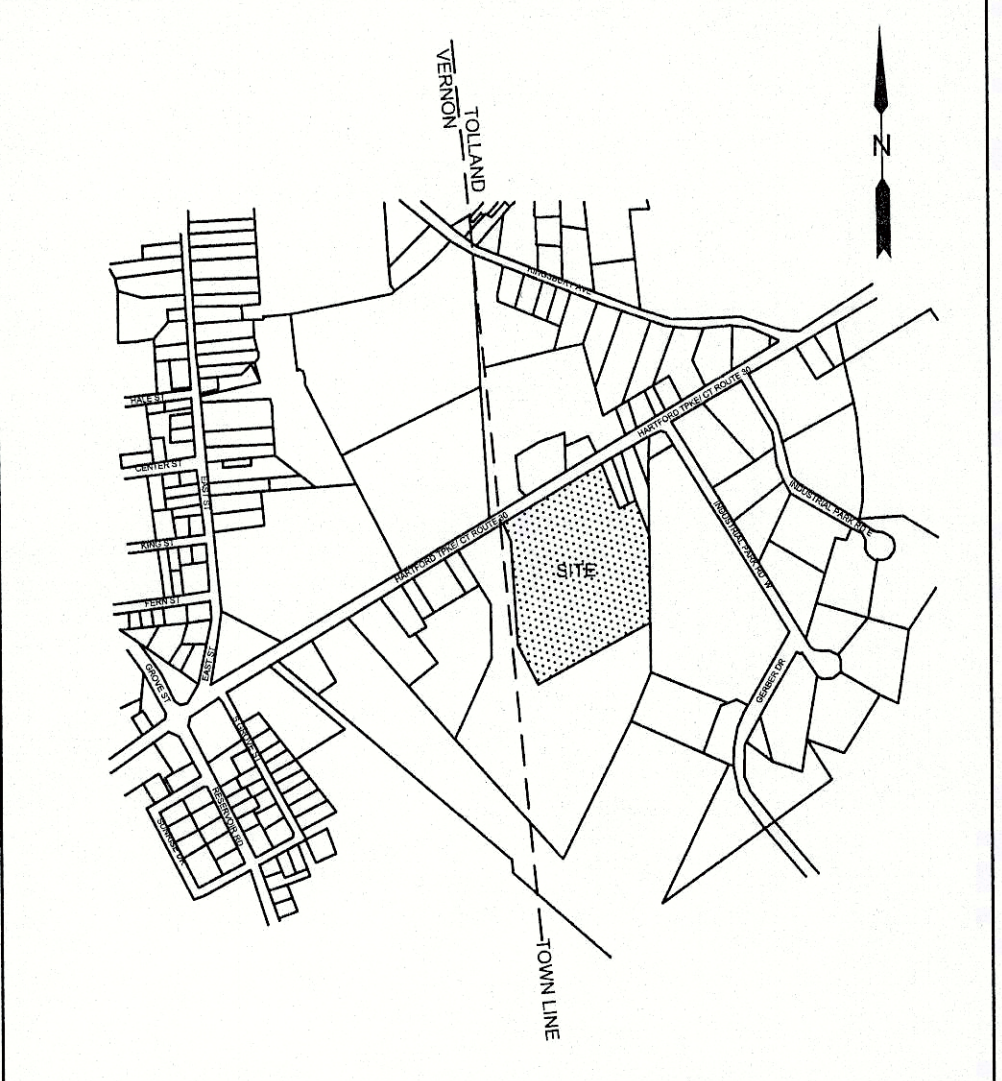

**SURVEY NOTES:**  
1) THIS SURVEY AND MAP HAS BEEN PREPARED IN ACCORDANCE WITH SECTIONS 20-300B-1 THRU 20-300B-20 OF THE REGULATIONS OF CONNECTICUT STATE AGENCIES "MINIMUM STANDARDS OF ACCURACY, CONTENT AND CERTIFICATION FOR SURVEYS AND MAPS" AS ADOPTED BY THE CONNECTICUT ASSOCIATION OF LAND SURVEYORS INC. ON AUGUST 29, 2019. IT IS A LIMITED PROPERTY/BOUNDARY IMPROVEMENT LOCATION SURVEY MAP BASED ON A RESURVEY CONFORMING TO HORIZONTAL SURVEY ACCURACY CLASS A-2 AND TOPOGRAPHIC ACCURACY T-3. THE INTENT OF THIS MAP IS TO DEPICT THE LOCATION OF PROPOSED PARKING IMPROVEMENTS SHOWN WITH RESPECT TO THE APPLICABLE MUNICIPAL OR STATUTORY REQUIREMENTS.  
2) PROPERTY IS LOCATED IN A CIZ-A ZONE.  
3) PROPERTY IS NOT LOCATED IN A FLOOD HAZARD ZONE A PER FIRM FLOOD INSURANCE RATE MAP COMMUNITY-PANEL NUMBER 0901710015A EFFECTIVE DATE APRIL 1, 1982.  
4) THE PROPERTY IS SHOWN ON THE TOWN OF TOLLAND ASSESSOR'S MAP 19 BLOCK B LOT 4.  
5) INLAND WETLANDS BOUNDARY SHOWN WAS TAKEN FROM MAP REFERENCE 1.  
6) THE TOPOGRAPHY SHOWN IS BASED ON NGVD 1988 DATUM.

**MAP REFERENCES:**  
1) PLAN PREPARED FOR KIRCHHOFF ACQUISITIONS, LLC 259 HARTFORD TURNPIKE TOLLAND, CT. LIMITED PROPERTY / IMPROVEMENT LOCATION SURVEY SCALE: 1" = 40' DATE: 9/25/2018 FILE NO. 2018-45 SHEET 1 OF 1 BUSHNELL ASSOCIATES LLC. CIVIL ENGINEERING AND LAND SURVEYING 563 WOODBRIDGE STREET MANCHESTER, CT. 06042

**CONSTRUCTION NOTES:**  
1) THE CONTRACTOR MUST CONTACT CALL-BEFORE-YOU-DIG AT 1-800-922-4455 AT LEAST 48 HOURS PRIOR TO THE START OF ANY CONSTRUCTION ACTIVITY.  
2) OWNER OR CONTRACTOR IS RESPONSIBLE FOR OBTAINING ALL NECESSARY PERMITS, INSPECTIONS AND APPROVALS.  
3) OWNER OR CONTRACTOR TO VERIFY ALL DIMENSIONS, LOCATIONS AND INFORMATION CONTAINED IN THESE PLAN PRIOR TO THE START OF CONSTRUCTION. THE ENGINEER SHALL BE NOTIFIED OF ANY DISCREPANCIES PRIOR TO THE START OF CONSTRUCTION.

- LEGEND**
- EXISTING CONNECTICUT HIGHWAY DEPARTMENT MERESTONE
  - EXISTING IRON ROD
  - EXISTING UTILITY POLE
  - CATCH BASIN
  - HYDRANT
  - TREE
  - EXISTING CONTOUR
  - - - PROPOSED CONTOUR
  - - - PROPOSED LIMIT OF DISTURBANCE
  - - - PROPOSED SILTFENCE/LIMIT OF DISTURBANCE

UTILITIES SHOWN ON THIS MAP WERE DERIVED FROM FIELD LOCATIONS AND EXISTING MAPPING CONTRACTOR TO VERIFY LOCATIONS AND DEPTH IN THE FIELD PRIOR TO THE START OF ANY CONSTRUCTION. "CALL BEFORE YOU DIG (1-800-922-4455)."

OWNER/APPLICANT: 259 HARTFORD TURNPIKE, LLC  
45 EASTDALE AVE. NORTH SUITE 200  
POUGHKEEPSIE NY 12603  
PROPOSED AREA OF DISTURBANCE: 6,650 SQ. FT. +/-

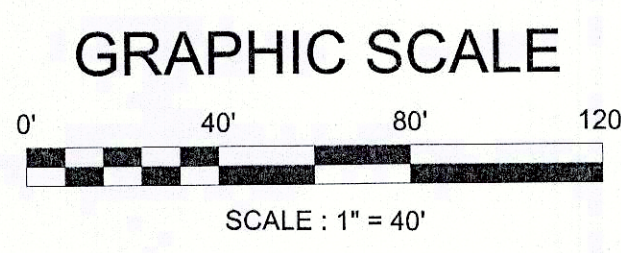

TO MY KNOWLEDGE AND BELIEF, THIS MAP IS SUBSTANTIALLY CORRECT AS NOTED HEREON.  
ANDREW F. BUSHNELL L.S. 24591  
THIS MAP IS NOT VALID WITHOUT A LIVE SIGNATURE AND EMBOSSED SEAL

	PLAN PREPARED FOR		
	KIRCHHOFF ACQUISITIONS, LLC		
259 HARTFORD TURNPIKE		TOLLAND, CT.	
IMPROVEMENT LOCATION SURVEY			
SCALE: 1"=40'	DATE: 5/7/2024	FILE NO. 2018-45	SHEET: 1 OF 2
BUSHNELL ASSOCIATES LLC.			
CIVIL ENGINEERING AND LAND SURVEYING		663 WOODBRIDGE STREET MANCHESTER, CT. 06042	
860-643-7875		REVISIONS:	

N/F  
259 HARTFORD TURNPIKE LLC  
566,389 SQ. FT.  
13.00 ACRES

N/F  
GERB TOLLAND QRS CT 16 INC  
24 INDUSTRIAL ROAD WEST  
CIZ-A ZONE

N/F  
TOLLAND COUNTY AGRICULTURAL CENTER INC  
269 HARTFORD TURNPIKE

EROSION AND SEDIMENTATION PLAN:

PROJECT: CONSTRUCTION OF ADDITIONAL ON-SITE PARKING

APPROXIMATE PROJECT START DATE: JULY 15, 2024  
 APPROXIMATE PROJECT COMPLETION DATE: SEPTEMBER 15, 2024

- 1.) EROSION AND SEDIMENTATION CONTROL ACTIVITIES TO CONFORM TO PRACTICES OUTLINED IN THE 2002 CONNECTICUT GUIDELINES FOR EROSION AND SEDIMENT CONTROL MANUAL.
- 2.) PRIOR TO SITE DISTURBANCE INSTALL SILT FENCE AT LOCATIONS SHOWN ON THE MAP. INSTALL SEDIMENT CONTROL MEASURES AT CATCH BASINS RECEIVING STORM WATER RUN OFF FROM THE DISTURBED AREAS. ADDITIONAL EROSION AND SEDIMENTATION CONTROL MEASURES MAYBE REQUIRED AS FIELD CONDITIONS REQUIRE.
- 3.) INSPECT AND REPAIR AS REQUIRED EROSION AND SEDIMENTATION CONTROL MEASURES PERIODICALLY, ALSO BEFORE AND AFTER LARGE RAIN STORMS. REMOVE SEDIMENT BUILD UP FROM SILT FENCE, CATCH BASIN SILT SACKS AND SUMPS AS REQUIRED.
- 4.) CONSTRUCT PARKING AREAS AS SHOWN.
- 5.) SPREAD TOPSOIL, MACHINE RAKE, FERTILIZE, SEED AND MULCH DISTURBED AREAS AS SOON AS POSSIBLE. USE A GRASS SEED MIXTURE BASED ON SITE CONDITIONS (i.e. SUN OR SHADE) AND THE SEASONAL WEATHER CONDITIONS.
- 6.) REMOVE ALL EROSION AND SEDIMENTATION CONTROL MEASURES AFTER ENTIRE SITE HAS BEEN STABILIZED AND PERMANENT GROUND COVER GROWTH HAS MATURED.

**SITE SEEDING NOTES:**  
 PREPARATION: FINE GRADE AND RAKE SOIL SURFACE TO REMOVE STONES LARGER THAN 2" IN DIAMETER. INSTALL SEEDED EROSION CONTROL DEVICES SUCH AS SURFACE WATER DIVERSIONS AS REQUIRED. APPLY LIMESTONE AT A RATE OF 2 TONS/AC. OR 80 LBS./1000 SQ.FT. FERTILIZE WITH 10-10-10 AT A RATE OF 300 LBS./AC. OR 7.5 LBS. PER 1000 SQ.FT. WORK LIME AND FERTILIZER INTO SOIL UNIFORMLY TO A DEPTH OF 4".  
 SEED APPLICATION: APPLY SEED MIXTURE FROM THE CHART BELOW BY HAND, CYCLONE SEEDER OR HYDRO SEEDER. INCREASE SEED MIXTURE BY 10% IF HYDRO SEEDER IS USED. LIGHTLY DRAG OR ROLL THE SEEDED SURFACE TO COVER SEED. SEEDING SHOULD BE DONE BETWEEN THE TIMES SHOWN ON THE CHART BELOW. IF SEEDING CANNOT BE DONE DURING THESE TIMES, REPEAT MULCHING PROCEDURE BELOW UNTIL SEEDING CAN TAKE PLACE.  
 MULCHING: IMMEDIATELY FOLLOWING SEEDING, MULCH THE SEED SURFACE WITH STRAW OR HAY AT A RATE OF 2 TO 3 TONS/AC. SPREAD MULCH BY HAND OR MULCH BLOWER. PUNCH MULCH INTO SOIL SURFACE WITH A TRACK MACHINE OR DISK HARROW SET STRAIGHT UP. IF USING HYDRO SEED MIX USE TACTIFIER ADDITIVES TO ADHERE MULCH MATERIAL TO THE SURFACE.

SEED SELECTION:	LB/1000 SQ. FT.	SEED MIXTURE	RECOMMENDED SEEDING DATES
PERMANENT LAWN	0.45	KENTUCKY BLUEGRASS	4/1-6/15
	0.45	CREeping RED FESCUE	8/15-10/1
	0.10	PERENNIAL RYEGRASS	
SLOPES & COARSE LAWN	0.45	CREeping RED FESCUE	4/1-6/15
	0.05	RED TOP	8/15-10/1
	0.45	TALL FESCUE	
SLOPES (NO MOWING)	1.8	CREeping RED FESCUE	4/1-6/15
	0.2	RED TOP	8/15-10/1
TEMPORARY COVER	3.0	WINTER RYE	4/15-6/15, 8/15-10/15
		OR	
	1.0	ANNUAL RYEGRASS	3/1-6/15, 8/1-10/15

IF SEED IS PLANTED OUTSIDE THE RECOMMENDED SEEDING DATES IRRIGATION MAYBE REQUIRED AT A UNIFORM APPLICATION RATE OF 1 TO 2 INCHES OF WATER APPLIED PER APPLICATION, SOAKING THE GROUND TO A DEPTH OF 4 INCHES.

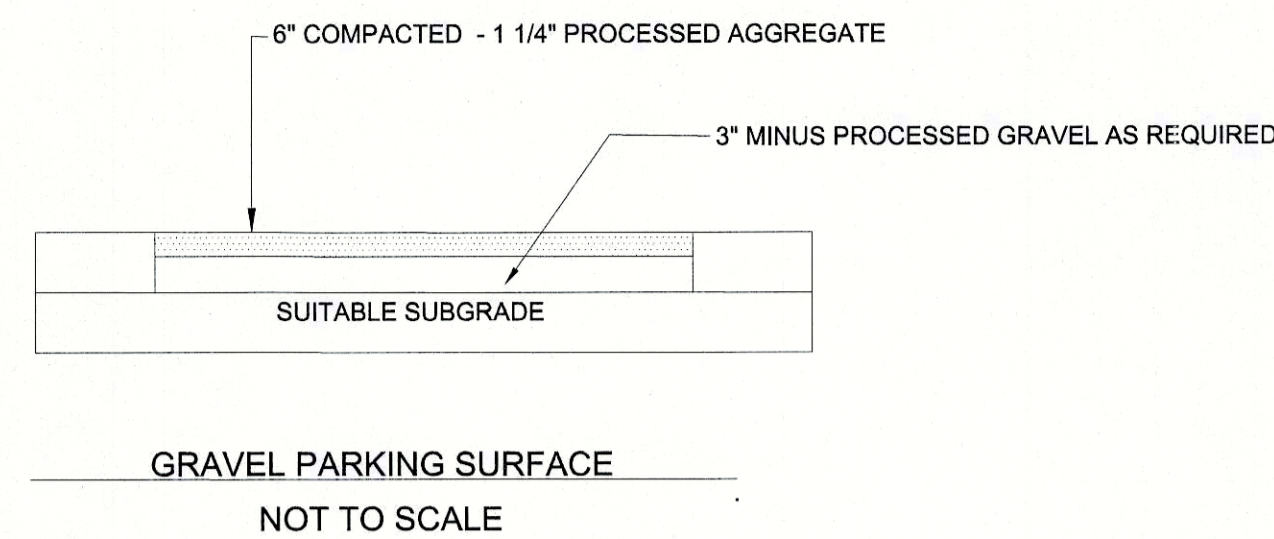
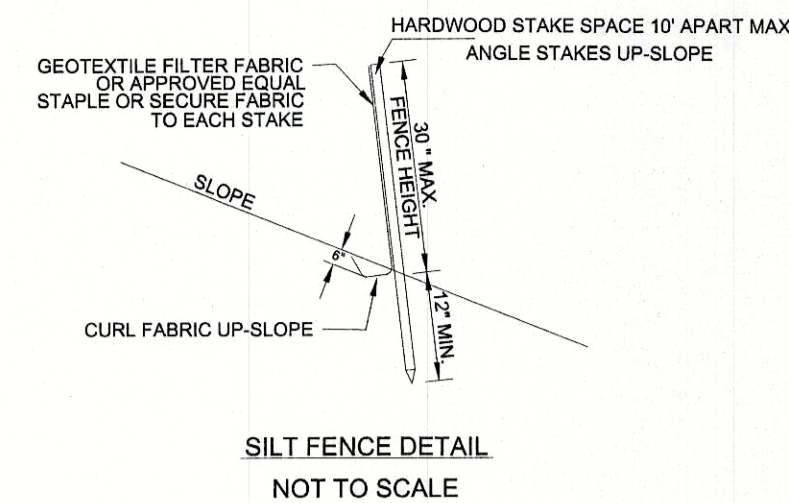

CONSTRUCTION NOTES:

- 1.) THE CONTRACTOR MUST CONTACT CALL-BEFORE-YOU-DIG AT 1-800-922-4455 AT LEAST 48 HOURS PRIOR TO THE START OF ANY CONSTRUCTION ACTIVITY.
- 2.) OWNER OR CONTRACTOR IS RESPONSIBLE FOR OBTAINING ALL NECESSARY PERMITS, INSPECTIONS AND APPROVALS.
- 3.) OWNER OR CONTRACTOR TO VERIFY ALL DIMENSIONS, LOCATIONS AND INFORMATION CONTAINED IN THESE PLAN PRIOR TO THE START OF CONSTRUCTION. THE ENGINEER SHALL BE NOTIFIED OF ANY DISCREPANCIES PRIOR TO THE START OF CONSTRUCTION.

THE LOCATIONS OF UTILITIES SHOWN ON THIS MAP ARE APPROXIMATE. THE LOCATIONS WERE DERIVED FROM FIELD LOCATIONS AND/OR EXISTING MAPPING. ADDITIONAL UTILITIES NOT SHOWN ON THIS MAP MAY EXIST. THE OWNER OR CONTRACTOR SHALL CONTACT CALL BEFORE YOU DIG (1-800-922-4455) PRIOR TO THE START OF ANY CONSTRUCTION TO VERIFY UTILITY LOCATIONS.

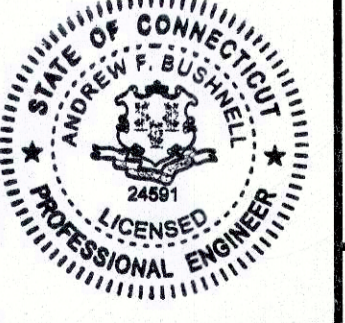
	<b>BUSHNELL ASSOCIATES LLC.</b> CIVIL ENGINEERING AND LAND SURVEYING 563 WOODBRIDGE STREET    MANCHESTER, CT. 06042 860-643-7875
	PLAN PREPARED FOR  <b>KIRCHHOFF ACQUISITIONS, LLC</b> 259 HARTFORD TURNPIKE    TOLLAND, CT.
<b>E&amp;S PLAN / CONSTRUCTION NOTES &amp; DETAILS</b>	
SCALE: NONE    DATE: 5/7/2024    FILE NO. 2018-45    SHEET: 2 OF 2	
REVISIONS:	

### Planning and Zoning Two Month Look Ahead

Meeting Date	Upcoming Items			
Monday, June 10, 2024	24-3 Large Lot Accessory Structures			
Monday, June 24, 2024				
Monday, July 8, 2024				
Monday, July 22, 2024				

**KEY**

- TO BE RECEIVED
- HEARINGS
- NEW/OLD BUSINESS
- OTHER

**Future Items:**

**Thu May 16, 2024**

**12pm - 12:40pm Basic Training Webinar Series - Virtual/online**

**Calendar:** CT Land Use Commissioner Training

**Created by:** donnadione.uconn@gmail.com

**Mon May 20, 2024**

**6pm - 8pm Land Use Commissioner Basic Training for ZBA Members - Virtual/online**

**Calendar:** CT Land Use Commissioner Training

**Created by:** david.dickson@uconn.edu

**Thu Jun 20, 2024**

**12pm - 12:40pm Basic Training Webinar Series - Virtual/online**

**Calendar:** CT Land Use Commissioner Training

**Created by:** donnadione.uconn@gmail.com

**Cassandra Santoro**

---

**Subject:** FW: [EXTERNAL]Unregulated Backyard Shooting Ranges  
**Attachments:** 20240513\_123433\_575854919556313.mp4; January 16.docx

---

**From:** David Corcoran <dcorcoran@Tollandct.gov>  
**Sent:** Monday, May 13, 2024 12:48 PM  
**To:** Cassandra Santoro <csantoro@Tollandct.gov>  
**Subject:** FW: [EXTERNAL]Unregulated Backyard Shooting Ranges

Can you please forward to the Commission and add as correspondence for the 3 PM packet

Thanks,  
David

---

**From:** Diana Norris <[dnorris300@comcast.net](mailto:dnorris300@comcast.net)>  
**Sent:** Monday, May 13, 2024 12:45  
**To:** David Corcoran <[dcorcoran@Tollandct.gov](mailto:dcorcoran@Tollandct.gov)>  
**Subject:** [EXTERNAL]Unregulated Backyard Shooting Ranges

And so, the Season of sitting in my beautiful backyard listening to the sound of gunfire begins. There is nothing more relaxing. I really wish town government would stop ignoring this problem and the detriment it is to quality of life in this town. I and others in conjunction with CAGV are working on this at the state level and already have multiple senators involved to try to enact state regulations that towns would have to follow but wouldn't it be nice if the town fixed their own problem?

Diana Norris  
300 Plains Road

Sent from my Galaxy



January 16, 2024

To: Tolland Town Council Members

Tolland Town Manager, Mr. Foley

Tolland Board of Zoning Members

Re: Back yard recreational shooting ranges

Dear Town Council, Town Manager, and Zoning Board Members,

My Name is Diana Norris and my husband, Jim, and I have resided at 300 Plains Road since August of 1990. We have always loved our little corner of the woods. As we live near state forest and have had neighbors, over the years, who hunt we grew accustomed to hearing gunshots during hunting season.

However, over the past decade there has been a progressive increase in target/recreational shooting at any time of year, any time of day in residential back yards within uncomfortable proximity to our home. I have called the Resident Troopers on multiple occasions over the years. One time I could visibly see from my yard a neighbor shooting at a target on a tree, and both the homeowner behind him and myself called the State Trooper who did come to assess. On other occasions I stood in the back yard with my phone so the officer could hear how loud and close the shooting was. We have had many family gatherings, picnics that were ruined by the sudden onset/barrage of shooting in the woods behind our home. Not just single shots but a barrage of shots. We have on occasion asked our grandchildren to come into the house. One of our neighbors found shell casings at the edge of his property.

I have over a period of years reached out to our resident troopers, Tammy Nuccio, a state senator, and even more recently to Mr. Foley. The state troopers confirmed my observations that the incidence of shooting in residential neighborhoods has increased in proportion to the increase in gun permits that they have granted. Tammy Nuccio and the Senator Gordon acknowledged my letters/emails but felt no need to assist me. I never received a response to the email I sent to Mr. Foley.

I am well aware of people's Second Amendment Rights and I do not wish to wade into that territory. However, all homeowners in this town have a right to public safety. I and many others I have spoken to agree that it is time to reevaluate the regulations regarding shooting in a residential neighborhood. Currently the requirement is to be 250 feet away from the nearest home. Not the property line but the home! I understand for hunting it is 500 feet. This is not adequate given the distance a bullet can travel. Also, per the State Troopers, when target shooting/recreationally shooting in a back yard one is supposed to be shooting into a berm. However back yard shooting ranges do not require a permit or inspection so there is no safety mechanism in place.

I strongly feel it is time the town government reviews the regulations for backyard/residential shooting as well as create a permit process for back yard shooting ranges. It is incredulous to me that we need permits for decks, sheds, pools, hot tubs, additions and other home improvements but no permit to set up a shooting range on one's property. The better alternative would be to target practice at an established shooting gallery vs. near residential homes but at least having safer regulations and permits for/inspections of shooting ranges would be an improvement in everyone's quality of life.

I am hopeful that as a former Police Detective, Mr. Foley will show an interest in improved gun safety in our town.

Sincerely,

Diana and Jim Norris

[Dnorris300@comcast.net](mailto:Dnorris300@comcast.net), 860 205-7145

**PLANNING & ZONING COMMISSION  
TOLLAND, CONNECTICUT  
REGULAR MEETING MINUTES OF APRIL 22, 2024**

**MEMBERS PRESENT:** Andy Powell, Chair  
Marilee Beebe, Vice Chair  
Joe Matteis  
Erin Stavens  
Amanda Hickey  
Brian Mead, alternate

**OTHERS PRESENT:** David Corcoran, Director of Planning & Development  
Chris Moran, Town Council Liaison  
Rita Zangari, Chair, Economic Development Commission

1. **Call to Order:** Andy Powell, Chair, called the meeting to order at 7:05 p.m. in Council Chambers.
2. **Pledge of Allegiance:** Recited.
3. **Seating of Alternates:** None.
4. **Additions to Agenda:** None.
5. **Public Comment:** None.
6. **Public Hearing(s):** None.
7. **Old Business:** None.
8. **New Business**

8.1 Draft Affordable Housing Plan Review – Mr. Corcoran noted that State statute requires an affordable housing plan be updated every five years, and the last time they did it was in 2019 as part of the full Plan of Conservation and Development (POCD). This time, they are pulling it out and doing it separately. In 2029 it will again be done as part of the POCD. It is due in September.

Mr. Corcoran assessed Tolland’s status with affordable housing based on the most recent census data from 2021. He added a progress report and the Commission looked at potential goals. He noted the PZC made a number of regulatory changes to support the building of affordable housing and he reviewed them as outlined in the draft.

Mr. Powell said it is important to prioritize up front the infrastructure limitations in town that make building affordable housing a challenge in Tolland. Mr. Matteis agreed. He questioned if they are making regulations in zones that will make it harder to build. His concern was that in five or ten years, they will be in the same place they are today, falling short of the ten percent goal.

Mr. Corcoran said it depends on what they see as success. He asked, have we created a mechanism that gives a builder the tools to build affordable? The answer is yes.

*April 22, 2024 – Tolland Planning & Zoning Commission*

Mr. Powell said the problem is that they are tied down by the economics involved. Tolland does not have the capital as a town to build affordable housing like some larger cities do. He said they are completely dependent on builders and if they cannot afford to build, then they aren't going to do it. He noted also that he has given testimony three times to the State Senate and twice to the State House of Representatives about this. The lack of jobs and transportation also make it a challenge.

Ms. Beebe agreed. She said they can't compel people to build, nor can they have the public subsidize it. Profit for the builder is always going to be the driver.

Ms. Hickey asked what happens to the money in the Affordable Housing Trust Fund? How can it be used? Mr. Corcoran said they will determine how to use it as it comes in. For example, it could be used for housing rehabilitation. It could be used to buy down deeds on existing properties so a housing unit could be made with 8-30g. Or, money could be used to help a developer add more affordable housing units. He noted also that while 8-30g is designed for larger developments, the Capitol Region Council of Governments (CROG) is aware of this and looking into it. Local developer Steve Williams had been looking for model documents he could use.

Ms. Hickey asked if anything had come of the grants manager finding funds for affordable housing. Mr. Corcoran said she secured a Small Cities Grant for Old Post Village and they plan to use it to do some rehabilitation work. Ms. Hickey asked if they could use the grants manager to seek out businesses to come to Tolland. Mr. Corcoran said that while that more likely falls under the purview of the Economic Development Commission, he suspected she might be able to do that. Ms. Beebe noted the new grants manager is doing some multi-tasking in her job, acting also as a project manager.

Ms. Beebe said she likes what they have accomplished in their efforts to promote affordable housing. She said they have enthusiastically been embracing the concept of affordable housing.

Mr. Matteis noted that from 2020 to 2024 the cost of housing and income have both increased substantially and so to require a builder to make housing that is affordable at the four-year-old affordable rate is unfair to builders. Mr. Corcoran said the State revises income rates annually, so they would be working off of 2023 numbers.

Mr. Powell suggested for members' homework that they look at the verbiage in the draft and the goals listed and see if they still agree with what is there.

Ms. Stavens asked what the asterisks indicate under the Summary of Housing Goals. Mr. Corcoran said they are carryovers and he will clarify that in the final plan. Mr. Matteis said #8 lists an aspirational goal of 20 to 25 percent affordable housing—and that goal is not realistic. There was agreement that something in the neighborhood of 5 percent would be more realistic.

Ms. Hickey asked if they are carrying over most of the same goals from 2017, does it appear like they are not achieving anything? Mr. Corcoran said it might be beneficial to set some new goals. Ms. Beebe said they could also indicate which goals they have accomplished or made progress on.

It was noted that a local bank closed its doors recently in town. This led to a larger conversation around the availability of financing and how to help builders to obtain it. Ms. Beebe said the larger towns understand how to tie people in, adding that it is always very difficult for small builders to build, a big reason due to their inability to get financing. It was noted that small developers often can't deal with the complexities of the programs offered by the Department of Economic and Community Development.

*April 22, 2024 – Tolland Planning & Zoning Commission*

Rita Zangari, Chair of the Economic Development Commission, said the EDC was involved with some of the incubators at Nerac but they needed to have a venture capitalist to get involved and it's very difficult to get that.

- 8.2 **PZC #24-3 – Zoning Regulation Amendment** – Request to amend Article 17 “Accessory Uses and Structures” to allow for lots greater than five acres to construct one structure in excess of the size of the principal structure of the home to a maximum of 10,000 square feet. Applicant: Town of Tolland. *Receive and set the Public Hearing for Monday, June 10, 2024.*

**MOTION:** Erin Stavens/Joe Matteis to receive and set the Public Hearing for PZC #24-3 for Monday, June 10, 2024. Mr. Matteis, Ms. Stavens, Ms. Hickey, Ms. Beebe and Mr. Powell voted to approve. Motion carried.

- 8.3 Appointment of Cassandra Santoro as Alternate ZEO

**MOTION:** Erin Stavens/Marilee Beebe to appoint Cassandra Santoro as Alternate ZEO. Mr. Matteis, Ms. Stavens, Ms. Hickey, Ms. Beebe and Mr. Powell voted in favor. Motion carried.

## 9. **Reports**

- 9.1 Town Council Liaison – Chris Moran, Town Council Liaison, said he looked into the question Mr. Matteis had raised at the last meeting about why Parker Place has had their taxes waived. He said under their lease, they make payments in lieu of taxes. However, in some prior years they were allowed to waive payments based on vacancies and making repairs. However, going forward, this will not continue.

Mr. Moran reported that the Town Council has selected a company to do the fire study. He said companies came in and refined their proposals. They will be looking at staffing and apparatus. Mr. Moran also said they are discussing Historic District Commission membership. They are also having an upcoming electronic recycling event.

Mr. Powell reminded everyone that there will be a referendum vote on May 7 at the Tolland Library Program Room. Early voting is not permitted, but absentee voting is allowed.

- 9.2 Economic Development Liaison - Rita Zangari, Chair, said the EDC held a meeting recently to review a document on the value of different types of industries, so they can take a look at what the town might want to invest in. They would have to consider also what industries would make sense for Tolland. She said they may possibly bring in a consultant to help them with this.

Going back to the earlier discussion on finding avenues of financing for developers, Ms. Zangari said the Town could get involved by making introductions to people at the State level who have finance backgrounds. She noted the State has contacts at banks with Small Business Administration projects. Beyond that, she said the Town has the authority to do tax abatements. She noted this was done for Dari Farms many years ago. However, she said usually the only times the State gets involved is for large urban developments like remediation projects. These types of jobs often promise a number of jobs and if those jobs don't materialize, they try to get back some of the funding they provided. She said they don't tend to invest in startups and incubator companies.

Ms. Zangari said when companies are registered in town, a letter gets sent out to the owners with contact information and highlights on what Tolland has to offer. She said these are often the small,

*April 22, 2024 – Tolland Planning & Zoning Commission*

largely invisible companies that are operated out of someone's home. The ones with storefronts are sent a certificate. She said they are trying to be more supportive of new businesses, noting it would be helpful to have a part time Economic Development person on staff under Mr. Corcoran's direction. It was noted that staffing is hard to fund through grant monies. Ms. Zangari said they are also still pursuing their community currency project and will keep the PZC posted on it as it progresses.

Ms. Beebe asked if there was anything else coming out of the Technology building at UConn. Ms. Zangari said it was built as a series of labs partnering with existing companies. She said staying in touch with the head of the building would be good, but companies that come out of the Business School would likely present a better opportunity for Tolland.

9.3 Capitol Region Council of Governments – No report.

9.4 Zoning Enforcement Report – Mr. Corcoran said they are continuing to get the usual springtime issues. They had thought the issue with the collection of trucks on Grant Hill Road had been resolved, but it is not, and they are working on it. Additionally, he's received complaints of a home occupation landscaping company growing too large.

9.5 Planning Update – Mr. Powell said they have their homework to do on the Affordable Housing goals. There is also the upcoming public hearing on large accessory buildings.

Mr. Corcoran reported that a 15,000 square foot medical office building – Tolland Medical Center, LLC – should probably be coming before them in the next few weeks. Mr. Corcoran reported that the owner of the gas station at 216 Merrow Road has applied for a demolition permit. Additionally, Tri-Town gymnastics has started construction on their project.

Mr. Powell noted he will not be here for the meeting on June 24.

10. **Other Business**: None.

11. **Correspondence**: There is a letter in Commissioners' packets indicating that Mansfield is starting work on their sign regulations to make them compliant. The regulations look similar to Tolland's. Mr. Matteis noted their regulations seem to be working out well and the only signs out there that shouldn't be appear to be the ones from out-of-town landscapers who put them up at every stop sign.

12. **Public Participation**: None.

13. **Approval of Minutes** – April 8, 2024 Regular Meeting

**MOTION**: Erin Stavens/Amanda Hickey to approve the April 8, 2024 Regular Meeting minutes as written. Ms. Hickey, Ms. Stavens, Mr. Matteis, Ms. Beebe, and Mr. Powell voted in favor. Motion carried.

14. **Adjournment**

**MOTION**: Marilee Beebe/Erin Stavens to adjourn the meeting and pay the clerk at 8:17 p.m. Mr. Matteis, Ms. Stavens, Ms. Hickey, Ms. Beebe and Mr. Powell voted in favor. Motion carried.

Respectfully submitted  
Annie Gentile  
Clerk