

Agenda
Tolland Design Advisory Board
21 Tolland Green, Tolland, Connecticut
Thursday, September 7, 2023 at 7:00 p.m., 2nd floor, Conference Room C

1. Call to Order
2. New Business
3. Old Business
 - 3.1. Review of ADA Improvements on the Tolland Green as requested by the Planning and Zoning Commission.
4. Approve Minutes – August 10, 2023 Special Meeting
5. Other Business
6. Adjournment

PREPARED FOR:
 TOWN OF
 TOLLAND

PROJECT LOCATION:
 TOLLAND GREEN
 SIDEWALK CONSTRUCTION

NORTH GREEN PLAN

No.	Submittal / Revision	App'd.	By	Date

Designed By: GPR/CEE	Drawn By: GPR	Checked By: CEE
Issue Date: 07/24/2023	Project No: 80817	Scale: 1" = 20'

Drawing No.:
 SHEET 3 OF 8

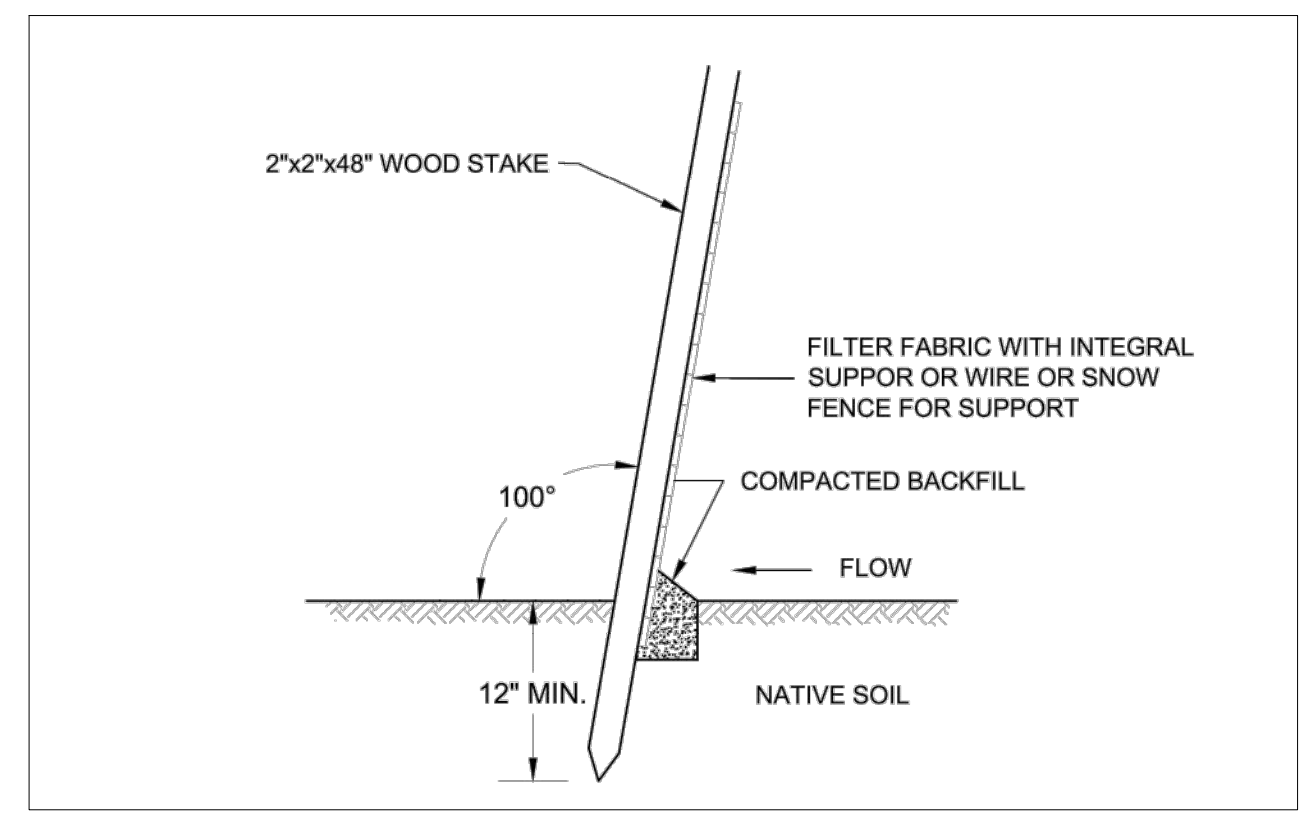

SILT FENCE INSTALLATION
 NTS

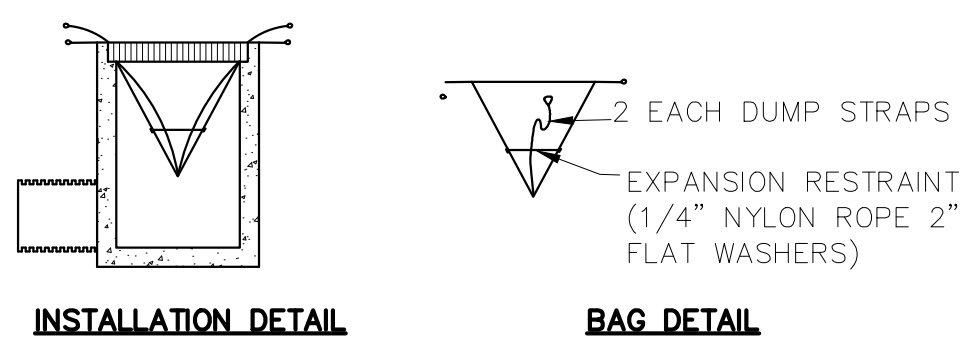

INSTALLATION DETAIL BAG DETAIL

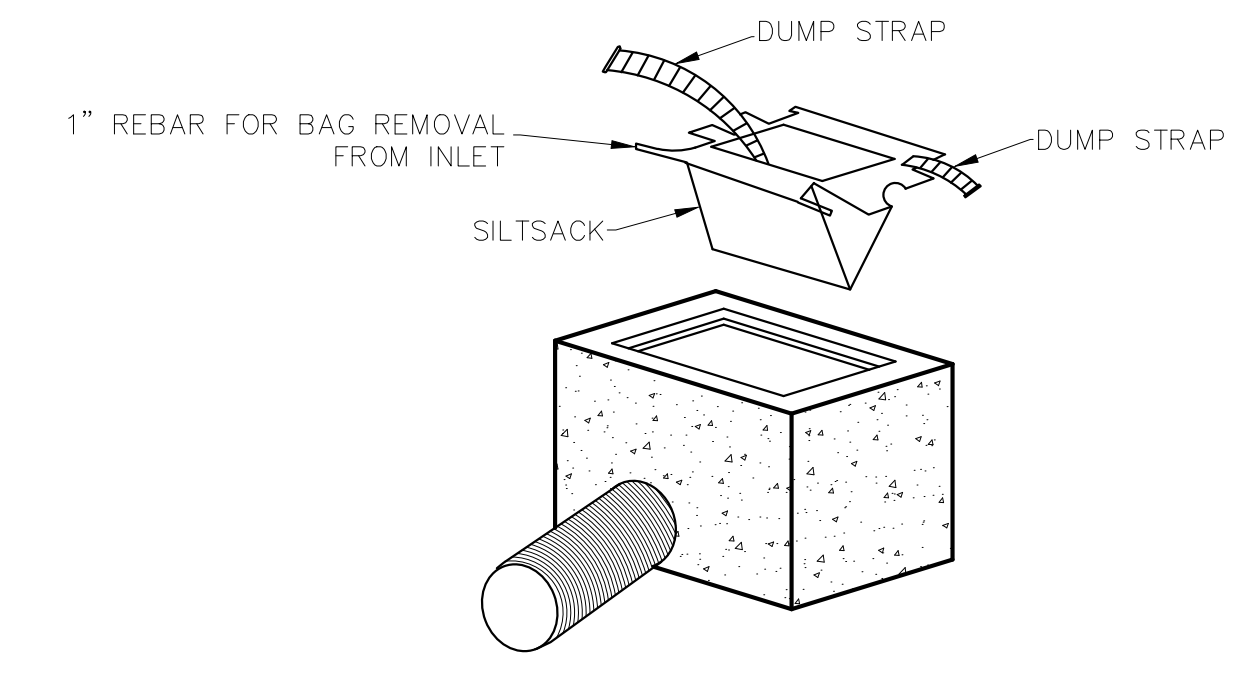

INLET SEDIMENT CONTROL DEVICE
 NTS

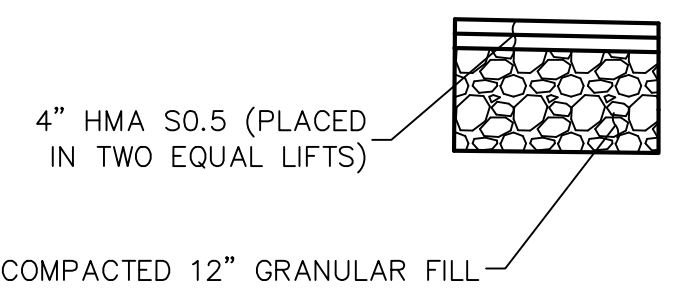

TYPICAL SECTION - PAVEMENT REPAIR
 NTS

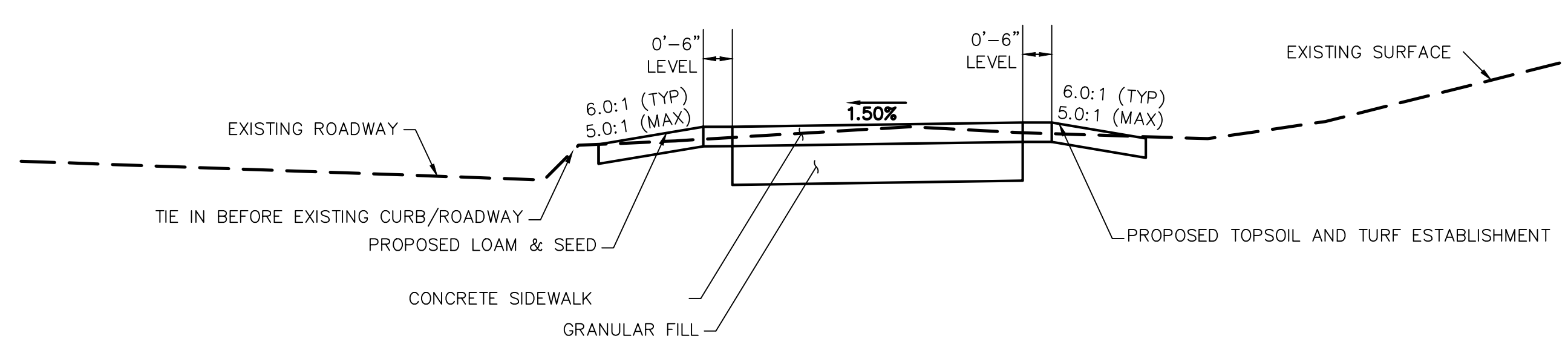

TYPICAL 4'-0" CONCRETE SIDEWALK
 NO CURBING
 NTS

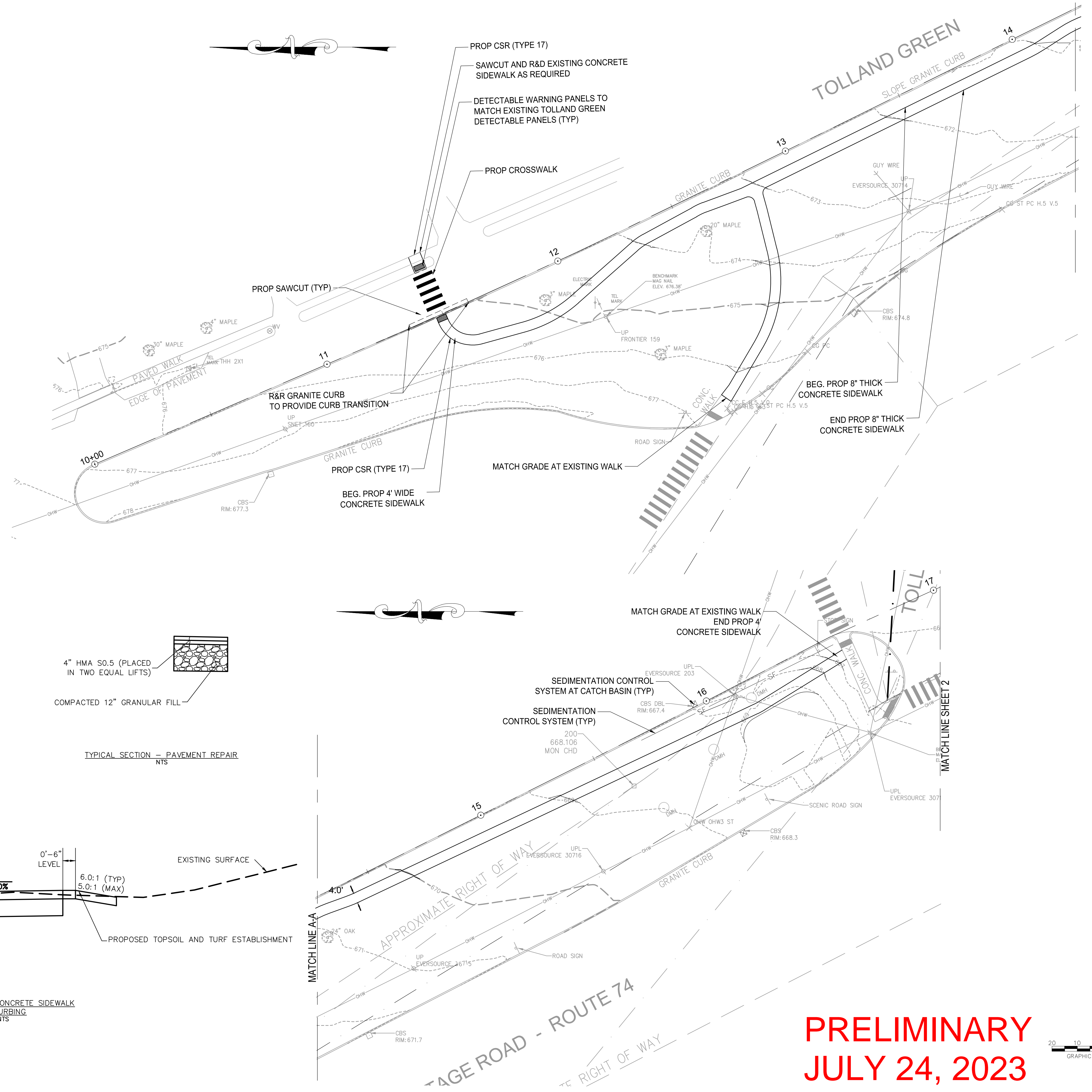

PRELIMINARY
JULY 24, 2023

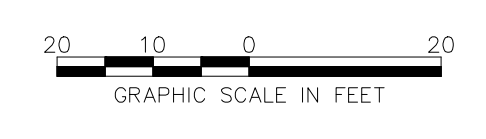

File: V:\PROJECTS\ANY\K6\080817\000_09_DESIGN_DRAWINGS\01_SHEETS\80817_HD.DWG

PREPARED FOR:
 TOWN OF
 TOLLAND

IT IS A VIOLATION OF LAW FOR ANY PERSON, UNLESS THEY ARE ACTING UNDER THE DIRECTION OF A LICENSED PROFESSIONAL ENGINEER, ARCHITECT, LANDSCAPE ARCHITECT OR LAND SURVEYOR TO ALTER OR USE IN ANY WAY, IF AN ITEM BEARING THE STAMP OF A LICENSED PROFESSIONAL IS ALTERED, THE ALTERING ENGINEER, ARCHITECT, LANDSCAPE ARCHITECT OR LAND SURVEYOR SHALL SIGN THE DOCUMENT AND INCLUDE THE NOTATION "ALTERED BY FOLLOWED BY THEIR SIGNATURE, THE DATE OF SUCH ALTERATION, AND A SPECIFIC DESCRIPTION OF THE ALTERATION."

PROJECT LOCATION:
 TOLLAND GREEN
 SIDEWALK CONSTRUCTION

No.	Submittal / Revision	App'd.	By	Date

SOUTH GREEN PLAN

Designed By: GPR/CEE	Drawn By: GPR	Checked By: CEE
Issue Date: 07/24/2023	Project No: 80817	Scale: 1" = 20'

Drawing No.:
 SHEET 4 OF 8

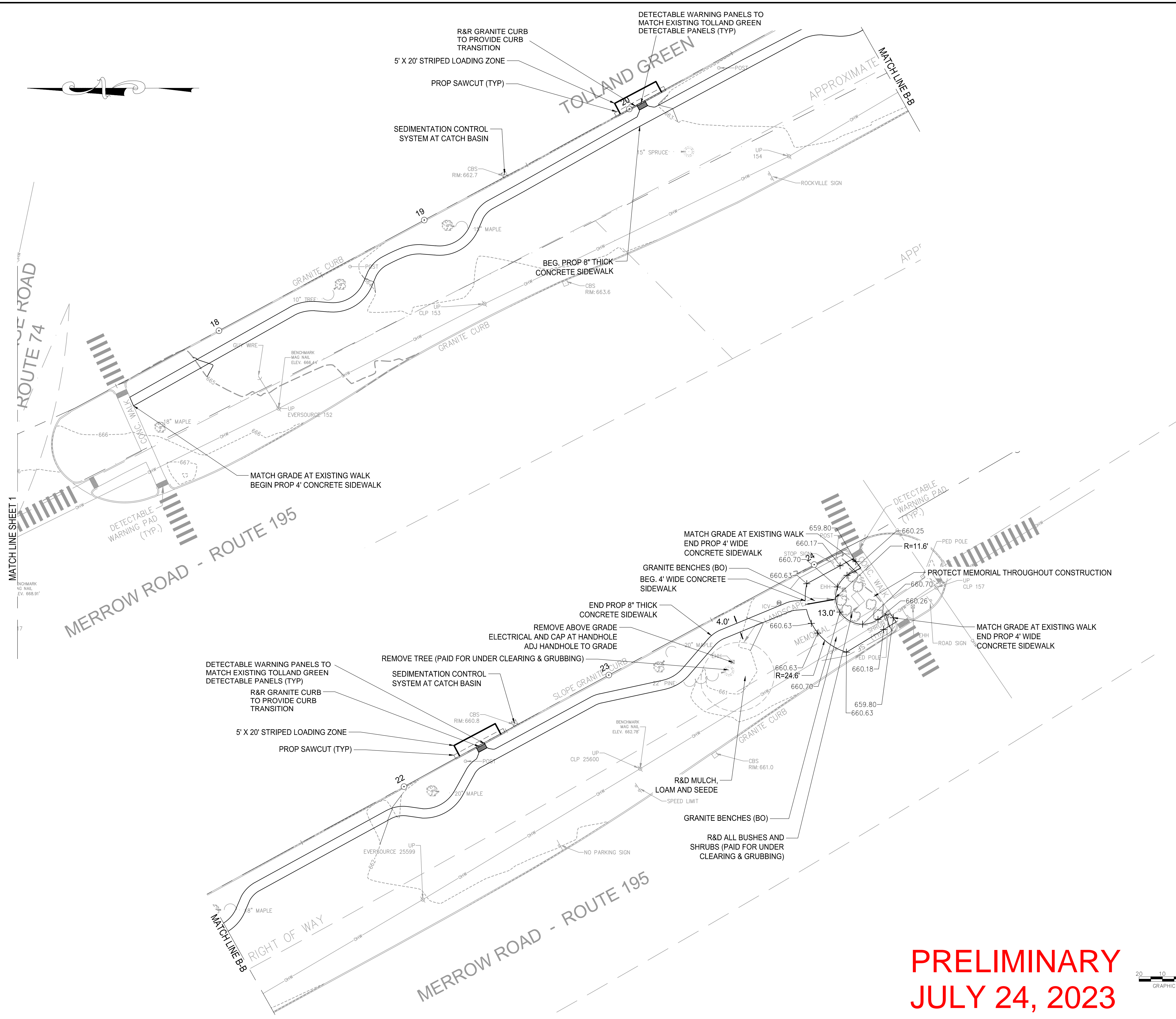

PRELIMINARY
JULY 24, 2023

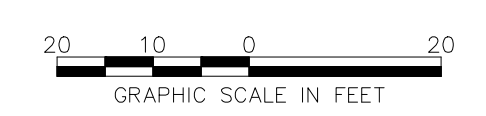

Tolland Design Advisory Board

Special Meeting Minutes—August 10, 2023

1. Call to Order

S. Nargardeolekar called the meeting to order at 7:05 PM

Members Present: S. Nargardeolekar (Chair), V. Nargardeolekar, K. Rogers

Staff Present: David Corcoran, Director of Planning and Development

Others Present: Jodie Coleman-Marzialo

2. New Business

2.1 Review of ADA Improvements on the Tolland Green as requested by the Planning and Zoning Commission

D. Corcoran presented the request from Planning and Zoning to the DAB to provide feedback by August 28th and explained the process to date. J. Coleman-Marzialo discussed the history of the sidewalk projects and efforts that have been made so far. The Board discussed several items, including the “why now?” need for the project, whether or not a sidewalk across the Green was actually necessary for ADA compliance instead of just providing access onto the green via curb cuts, whether or not it may be a better use of Town resources to contact different historic masons to look into re-setting the existing sidewalks parallel to the Green instead, and if it is appropriate to continue to use the Green for many of these larger scale town events following the DOT reconstruction of the Green.

The Board decided to defer on making any formal comment until after the Public Hearing scheduled for August 22nd.

3. Old Business

4. Approve Minutes – July 13, 2023 Special Meeting

V. Nargardeolekar moved and K. Rogers seconded to approve the July 13, 2023 Meeting Minutes

5. Other Business

6. Adjournment

V. Nargardeolekar moved and K. Rogers seconded to adjourn at 8:20 PM